

# Weierstraß-Institut für Angewandte Analysis und Stochastik

im Forschungsverbund Berlin e.V.

Preprint

ISSN 0946 – 8633

## Direct computation of elliptic singularities across anisotropic, multi-material edges

Robert Haller-Dintelmann<sup>1</sup>, Hans-Christoph Kaiser<sup>2</sup>,

Joachim Rehberg<sup>3</sup>

submitted: September 14th, 2009

<sup>1</sup> Technische Universität Darmstadt  
Schlossgartenstr. 7, 64289 Darmstadt, Germany  
E-Mail: haller@mathematik.tu-darmstadt.de

<sup>2</sup> Weierstrass Institute for  
Applied Analysis and Stochastics  
Mohrenstr. 39, 10117 Berlin, Germany  
E-Mail: kaiser@wias-berlin.de

<sup>3</sup> Weierstrass Institute for  
Applied Analysis and Stochastics  
Mohrenstr. 39, 10117 Berlin, Germany  
E-Mail: rehberg@wias-berlin.de

No. 1439  
Berlin 2009



---

2000 *Mathematics Subject Classification.* 35B65, 35J25, 35R05.

*Key words and phrases.* Elliptic transmission problems, mixed boundary problems,  $W^{1,p}$  regularity.

Edited by  
Weierstraß-Institut für Angewandte Analysis und Stochastik (WIAS)  
Mohrenstraße 39  
10117 Berlin  
Germany

Fax: + 49 30 2044975  
E-Mail: [preprint@wias-berlin.de](mailto:preprint@wias-berlin.de)  
World Wide Web: <http://www.wias-berlin.de/>

---

*2000 Mathematics Subject Classification* : 35B65, 35J25, 35R05

*Keywords* : Elliptic transmission problems, mixed boundary problems,  $W^{1,p}$  regularity.

*Abstract* : We characterise the singularities of elliptic div-grad operators at points or edges where several materials meet on a Dirichlet or Neumann part of the boundary of a two- or three-dimensional domain. Special emphasis is put on anisotropic coefficient matrices. The singularities can be computed as roots of a characteristic transcendental equation. We establish uniform bounds for the singular values for several classes of three- and four-material edges. These bounds can be used to prove optimal regularity results for elliptic div-grad operators on three-dimensional, heterogeneous, polyhedral domains with mixed boundary conditions. We demonstrate this for the benchmark L-shape problem.

“However, one can find these eigenvalues very seldom, [...] even in the case of the Laplace operator.” [37, p. 36]

## 1 Introduction

Regularity for elliptic div-grad operators  $-\nabla \cdot \mu \nabla$  on three-dimensional, heterogeneous, polyhedral domains is intimately connected with edge and vertex singularities, see [34], [35], [45], [46], [23], [42], [14], [47], [16], [15]. The focus of this paper is on characterising these singularities as the roots of a transcendental equation which is explicitly given in terms of the data. This allows for a scheme to compute the singularities, but also for estimates of these singularities. Despite the importance of appraising singularities, up to now there are no results for the case of several anisotropic materials — apart of [30], [18], and [24] for two materials. Ultimately, we aim at the integrability of the gradient of the solution of elliptic equations in div-grad form to an index larger than three. This property is very useful in the treatment of nonlinear equations and systems, see for instance [27], [48], [21], [20]. Due to a pioneering idea of V. Maz’ya it suffices to delimitate the edge singularities in order to get optimal elliptic regularity, see [48], [18].

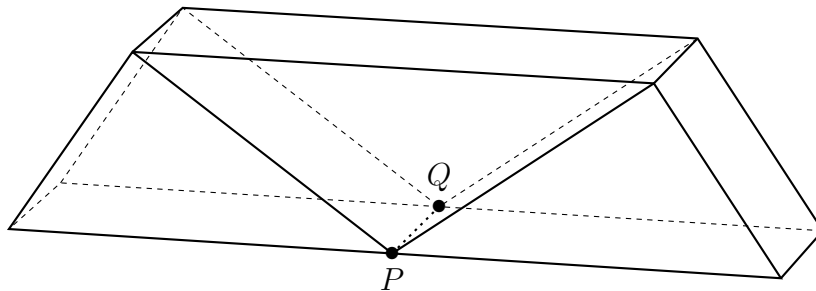
Since information about the singularity of solutions of elliptic equations is crucial for the solution of these equations and in particular for the efficiency of numerical solvers, there exist several numerical approaches to determine the singularities of specific anisotropic problems, see [42], [13], [58] and references cited there. For a more general numerical approach to heterogeneous elliptic problems see for instance [9], [1], [60], [29].

Div-grad operators  $-\nabla \cdot \mu \nabla$  are of significance in science and engineering. They abound in thermodynamics [55], [33], in electrodynamics [57], [40], in acoustics [59], [41], neutron transport theory [2] and references cited there, and mathematical biology [11], [5]. Moreover, such operators occur in semiconductor and laser modeling [56], for instance in the description of submicron devices by means of an effective mass Schrödinger operator in Ben Daniel Duke form [4], [62], [17], [44], [61]. The coefficient function  $\mu$  represents material properties as the context requires. It may be the dielectric permittivity in a Poisson equation, or diffusivity in a transport equation (see for instance [56, §2.2] for carrier continuity equations), or the effective electron mass in a Schrödinger equation (see for instance [36]). Let us emphasise that it is in the nature of the coefficient function  $\mu$  to be a tensor, though it simplifies in some applications to scalars. For a reasoning in electrodynamics see [54, Ch. IX], [40, Ch. XI], [39, §122], and for one in thermodynamics see [55, Ch. I.5] or [33, Ch. 2.1] and references cited there.

In the majority of cases  $\mu$  is discontinuous, if different materials meet at

surfaces or edges. Increasingly, one becomes aware that it is often not admissible to smooth out these discontinuities and to pass to smooth (or even constant) coefficient functions. For acoustics of heterogeneous media it was already pointed out by Tappert [59, p. 263] that the — formal — transformation of the reduced wave equation (in case of a time harmonic dependence) to the classical Helmholtz equation is of limited value, if the density changes abruptly. Analogous observations were made in mathematical biology [11], [5] and references cited there. In many advanced semiconductor devices heterostructures essentially determine the functionality see for instance [31], [7], [3]. Moreover, in semiconductor physics the effective mass theorem necessitates parameter discontinuities at the interface [17, Ch. I.III.3]. In all these contexts elliptic equations (for instance Poisson's equation) play a role, often as part of a compound model.

Information about the singularity of solutions of elliptic div-grad equations is encoded in a transcendental equation, see [14, Ch. 17] and [48, §3.4]. For edges, adjacent to two materials, this transcendental equation governing the singular values is known explicitly even in the case of anisotropic materials, see [18] and the Appendix of [24]. On the other hand there is next to nothing for multi-material edges notwithstanding their relevance in technology. The direct vision prism, for instance, features a three-material edge [26], [6, Ch. 3.2], see also Figure 1. At a three-material edge, even for scalar coefficients, the singular values in general have an arbitrarily small real part, see [49] and references cited there.



**Figure 1:** Direct vision prism composed of crown and flint glass (double Amici prism). At the three-material edge  $\overline{PQ}$  optical crown, flint, and again crown meet.

In contrast to stress calculations for anisotropic materials on three-dimensional domains (see [64], [51]) the somewhat related problem of elliptic edge singularities allows for an explicit, analytical treatment. We undertake this for up to four materials meeting at an edge, but it could be done similarly for an arbitrary number of materials.

In Section 2.1 the investigation of the edge singularities is reduced via

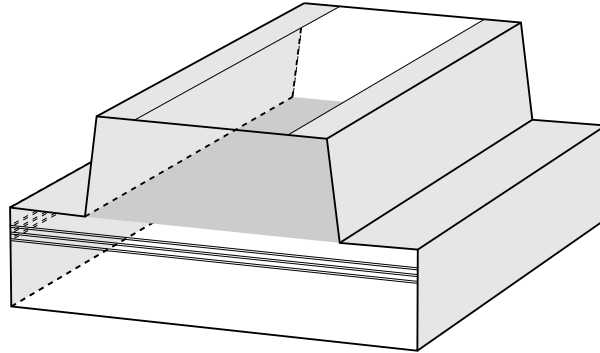
partial Fourier transform along the edge to the dissection of the vertex singularities for an associated two dimensional elliptic problem. The computation of the vertex singularities follows the approach of Costabel, Dauge, and Lafranche in [13], see also [12]. There elementary solutions of the associated generalised Sturm-Liouville problem are used to calculate the elliptic singularities. While Costabel et al. [13] describe a semi-analytic computation, here we explicitly get an analytic function, the roots of which are the singular values, see Theorem 2.19. This allows to obtain explicit bounds for the singularities in certain classes of material-geometric constellations. In general the singular values are complex numbers. Here we prove for certain classes that they are in fact real numbers. This rests on the way we derive the transcendental equation. Indeed, we encode each anisotropy (including the corresponding sectorial angle) in a scalar  $\kappa$  which enters the analytic function as a parameter. This parameter  $\kappa$  has the quality of an angle, and it represents exactly the deviation from the isotropic case. Thus, it is possible to emulate some results from the scalar coefficients case [52] in the case of anisotropic coefficients.

Section 2 is devoted to the precise formulation and the proofs of our main results concerning the analytic function whose zeros are the singular values. Furthermore, an estimate for the size of the sector containing the singular values is given in terms of the coefficient matrices. Then in Section 3 we give bounds for the singular values in some special cases, in particular for three materials meeting at an edge. In Section 4 we outline how to compute the zeros of the analytic function characterising the singular values, but do not expatiate on the numerical methods to do so since there is a vast specialised literature, see e.g. [38], [22], and references cited there.

Finally, in Section 5 we apply our result to the three-dimensional L-shape of different materials, see Figure 7 and Theorem 5.6, which was regarded in [15, Fig. 2] and [50, Fig. 1]. This kind of structure really plays a role in technology. Just have a look at a ridge waveguide multiple quantum well laser Figure 2.

Our result generalises that by Nicaise and Sändig [50] to anisotropic coefficient functions. Moreover, we provide an optimal regularity result within the scale of  $W^{1,q}$  spaces. This scale has the advantage — in contrast to the mostly considered scale of  $H^{s,2}$  spaces — that the space of optimal regularity embeds into a Hölder space. Thus, it allows for a unified treatment of quasi-linear parabolic equations, see [48], [27], and [25].

Summing up: With this investigation we would like to provide a tool to appraise the singularities at a multi-material edge, including anisotropies. Indeed it is well known in engineering that multi-material edges may cause difficulties. Therefore one tries to avoid them, but, this is not always possible,



**Figure 2:** Schema of a ridge waveguide quantum well laser (detail  $3.2\mu\text{m}\times 1.5\mu\text{m}\times 4\mu\text{m}$ ). A material interface (dark shaded) and a boundary part (light shaded) carrying Neumann boundary conditions meet at an edge of the device domain. At the bottom and the top of the structure are contacts giving rise to Dirichlet boundary conditions for the electrostatic potential in the electronic simulation of the laser, while other parts of the device are insulated (Neumann boundary conditions). A triple quantum well structure is indicated where the light beam forms in the symmetry plane of the domain.

as the ridge waveguide laser design demonstrates.

## 2 Singularities

In this section we first briefly recall how singular values originate from the elliptic equation on a two-dimensional domain. This exposition faithfully follows the standard way by Mellin transform, see [34], [37, Ch. 6.1], compare also [42, Ch. V.3]. Then we prove, after some preliminary work, our main Theorem 2.19 on the location of the singular values.

### 2.1 Preliminaries

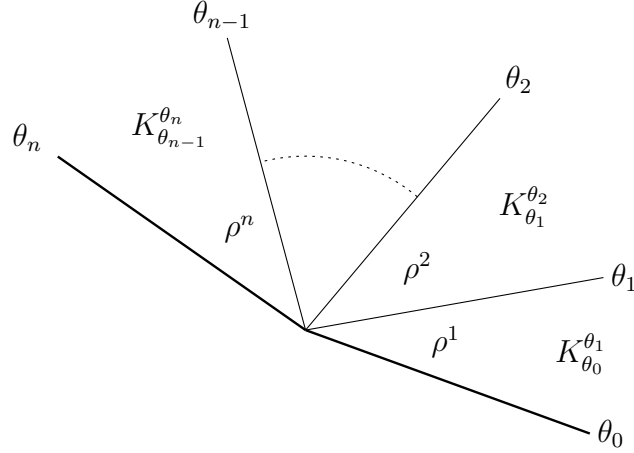
Let us define for any two complex numbers  $\sigma$  and  $\lambda$  the exponential by

$$\sigma^\lambda \stackrel{\text{def}}{=} \exp(\lambda \log |\sigma| + i\lambda \arg \sigma), \quad \arg \sigma \in ]-\pi, \pi]. \quad (2.1)$$

For two real numbers  $\tau$  and  $\nu$  with  $\tau < \nu < \tau + 2\pi$  we define the sector

$$K_\tau^\nu \stackrel{\text{def}}{=} \{(r \cos \theta, r \sin \theta) : r > 0, \theta \in ]\tau, \nu[ \}. \quad (2.2)$$

Now we introduce the relevant div-grad operators on 2-dimensional domains.



**Figure 3:** Material sectors  $K_{\theta_{j-1}}^{\theta_j}$  of the plane with corresponding coefficient matrices  $\rho^j$ ,  $j = 1, \dots, n$ . The thick lines bear Dirichlet or Neumann boundary conditions. See also Definition 2.1.

**Definition 2.1.** Let real numbers

$$\theta_0 < \theta_1 < \dots < \theta_n < \theta_0 + 2\pi$$

be given and, additionally, real, symmetric, positive definite  $2 \times 2$  matrices  $\rho^1, \dots, \rho^n$ , see Figure 3. We define  $\rho$  as the matrix valued function on  $K_{\theta_0}^{\theta_n}$  which takes on the sector  $K_{\theta_{j-1}}^{\theta_j}$  the value  $\rho^j$ . Let for any closed subspace  $\mathcal{V} \subset W^{1,2}(K_{\theta_0}^{\theta_n})$  the following sesquilinear form be given:

$$\mathcal{V} \times \mathcal{V} \ni (v, w) \mapsto \int_{K_{\theta_0}^{\theta_n}} \rho \nabla v \cdot \nabla \bar{w} \, dx. \quad (2.3)$$

We give the name  $-\nabla \cdot \rho \nabla$  with *Neumann boundary condition* to the operator corresponding to  $\mathcal{V} = W^{1,2}(K_{\theta_0}^{\theta_n})$  and the form (2.3), and we give the name  $-\nabla \cdot \rho \nabla$  with *Dirichlet boundary conditions* to the operator corresponding to  $\mathcal{V} = W_0^{1,2}(K_{\theta_0}^{\theta_n})$  and the form (2.3).

**Remark 2.2.** We restrict this investigation to real, symmetric matrices  $\rho$  because it makes use of results from [48] for such coefficient matrices. However, this case covers a lot of equations involving elliptic div-grad operators from mathematical physics and engineering. For a detailed discussion see [40, Ch. XI] and [39, §122].

**Definition 2.3.** Let  $\theta_0, \dots, \theta_n$  and  $\rho^1, \dots, \rho^n$  be as in Definition 2.1. We introduce on  $] \theta_0, \theta_n[ \setminus \{ \theta_1, \dots, \theta_{n-1} \}$  three coefficient functions  $b_0$ ,  $b_1$  and



$b_2$ , and the determinant  $D$  of  $\rho$ , whose restrictions to each of the intervals  $]\theta_{j-1}, \theta_j[$  are given by

$$\begin{aligned} b_0(\theta) &\stackrel{\text{def}}{=} \rho_{11}^j \cos^2 \theta + 2\rho_{12}^j \sin \theta \cos \theta + \rho_{22}^j \sin^2 \theta, \\ b_1(\theta) &\stackrel{\text{def}}{=} (\rho_{22}^j - \rho_{11}^j) \sin \theta \cos \theta + \rho_{12}^j (\cos^2 \theta - \sin^2 \theta), \\ b_2(\theta) &\stackrel{\text{def}}{=} \rho_{11}^j \sin^2 \theta - 2\rho_{12}^j \sin \theta \cos \theta + \rho_{22}^j \cos^2 \theta, \\ D(\theta) &\stackrel{\text{def}}{=} D_j \stackrel{\text{def}}{=} \det \rho^j = b_2 b_0 - b_1^2, \end{aligned} \tag{2.4}$$

$j = 1, \dots, n$ . If  $-\nabla \cdot \rho \nabla$  is complemented with Dirichlet conditions, then we define the space  $\mathcal{H}$  as  $W_0^{1,2}(\theta_0, \theta_n)$ , while in the case of Neumann conditions we set  $\mathcal{H} = W^{1,2}(\theta_0, \theta_n)$ . For every  $\lambda \in \mathbb{C}$  we then define the quadratic form  $\mathfrak{t}_\lambda$  on  $\mathcal{H}$  by

$$\mathfrak{t}_\lambda[\psi] \stackrel{\text{def}}{=} \int_{\theta_0}^{\theta_n} b_2 \psi' \overline{\psi'} + \lambda b_1 \psi \overline{\psi'} - \lambda b_1 \psi' \overline{\psi} - \lambda^2 b_0 \psi \overline{\psi} \, d\theta$$

and  $\mathcal{A}_\lambda$  is the operator which is induced by  $\mathfrak{t}_\lambda$  on  $L^2(\theta_0, \theta_n)$ .

**Remark 2.4.** It is easy to check that  $b_2$ , restricted to the interval  $]\theta_{j-1}, \theta_j[$ , is bounded from below by the smallest eigenvalue of the matrix  $\rho^j$ . Indeed,

$$\begin{aligned} \inf_{\theta \in ]\theta_{j-1}, \theta_j[} b_2(\theta) &= \inf_{\theta \in ]\theta_{j-1}, \theta_j[} \begin{pmatrix} \rho_{11}^j & \rho_{12}^j \\ \rho_{12}^j & \rho_{22}^j \end{pmatrix} \begin{pmatrix} -\sin \theta \\ \cos \theta \end{pmatrix} \cdot \begin{pmatrix} -\sin \theta \\ \cos \theta \end{pmatrix} \\ &\geq \inf_{\xi \in \mathbb{R}^2, \|\xi\|=1} \rho^j \xi \cdot \xi \geq \inf_{\xi \in \mathbb{C}^2, \|\xi\|=1} \rho^j \xi \cdot \bar{\xi} \end{aligned}$$

By the minimax principle, the last term equals the smallest eigenvalue of  $\rho^j$ , which is easy to evaluate as

$$\frac{\rho_{11}^j + \rho_{22}^j}{2} - \sqrt{\frac{(\rho_{11}^j - \rho_{22}^j)^2}{4} + (\rho_{12}^j)^2}$$

and is greater than 0 due to the condition from Definition 2.1. Hence, the form  $\mathfrak{t}_\lambda$  is sectorial for every  $\lambda \in \mathbb{C}$ . A fortiori the induced operator  $\mathcal{A}_\lambda$  is sectorial, see [32, Ch. VI].

**Definition 2.5.** We call  $0 \neq \lambda \in \mathbb{C}$  with  $\Re \lambda \in [0, 1[$  a singular value for the operator  $-\nabla \cdot \rho \nabla$  (including boundary conditions), iff the corresponding operator  $\mathcal{A}_\lambda$ , see Definition 2.3, has a nontrivial kernel.

Indeed it is well known that, if  $\lambda$  is a singular value for  $-\nabla \cdot \rho \nabla$  and  $\psi_\lambda$  is an element from  $\ker \mathcal{A}_\lambda$ , then the function

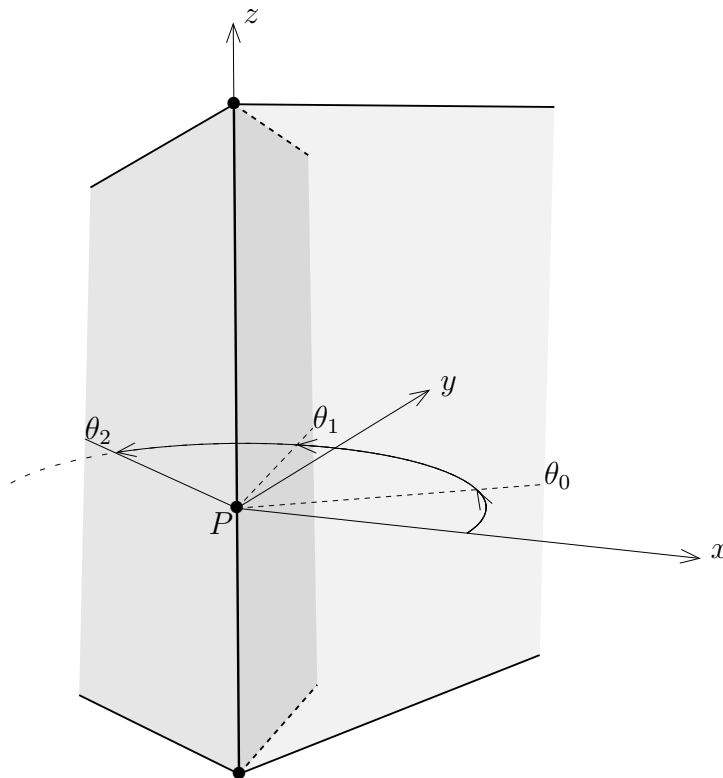
$$h: \mathbb{R}^2 \ni (x, y) \mapsto (x^2 + y^2)^{\frac{\lambda}{2}} \psi_\lambda(\arg(x + iy))$$

satisfies the equation  $-\nabla \cdot \rho \nabla h = 0$  on  $K_{\theta_0}^{\theta_n}$  in the sense that

$$\int_{K_{\theta_0}^{\theta_n}} \rho \nabla h \cdot \nabla \bar{w} \, dx = 0 \quad \text{for all } w \in \mathcal{V} \text{ with compact support,}$$

see also (2.3). Since  $\Re \lambda < 1$  the partial derivatives of  $h$  have a singularity in  $0 \in \mathbb{R}^2$ .

Let us next briefly recall the connection between elliptic three-dimensional edge singularities and two-dimensional vertex singularities.



**Figure 4:** Edge pencil, see Definition 2.6

**Definition 2.6.** Let  $\Omega \subset \mathbb{R}^3$  be a polyhedron which, additionally, is a Lipschitz domain (that means a domain of class  $C^{0,1}$ ) and let  $\{\Omega_k\}_k$  be a finite,

disjoint, polyhedral partition of  $\Omega$ . Hence, the boundary  $\partial\Omega$  is the disjoint union of some faces, edges, and vertices of the polyhedra  $\Omega_k$ . Furthermore,  $\mu$  shall be a matrix function on  $\Omega$  which is constant on each  $\Omega_k$  and takes real, symmetric, positive definite  $3 \times 3$  matrices as values. Moreover, the faces of the sub-polyhedra  $\Omega_k$ , which are open sets with respect to the surface measure, are either in the interior of  $\Omega$ , or carry Neumann boundary conditions, or carry Dirichlet boundary conditions. We regard now the edges of the sub-polyhedra  $\Omega_k$ , which are open sets with respect to the curve measure, thus do not contain any vertex of  $\Omega_k$ . Let  $E$  be such an edge on the boundary of  $\Omega$ , and let  $P$  be an arbitrary inner point of this edge. Choosing a new orthogonal coordinate system  $(x, y, z)$  with origin at the point  $P$  such that the direction of  $E$  coincides with the  $z$ -axis, we denote by  $\omega$  the corresponding orthogonal transformation matrix and by  $\mu_\omega$  the piecewise constant matrix function which satisfies in a neighbourhood  $\mathcal{O}$  of the origin

$$\begin{aligned}\mu_\omega(x, y, z) &= \omega \mu(\omega^{-1}(x, y, z)) \omega^{-1} \quad \text{for all } (x, y, z) \in \mathcal{O}, \\ \mu_\omega(tx, ty, z) &= \mu_\omega(x, y, 0) \quad \text{for all } (x, y, 0) \in \mathcal{O}, z \in \mathbb{R}, \text{ and } t > 0.\end{aligned}$$

Finally, we denote by  $\mu_E$  the upper left  $2 \times 2$  block of  $\mu_\omega$  at  $z = 0$ .

**Remark 2.7.** The matrix  $\mu_E$  is given on a sector (2.2) which coincides near  $P$  with the intersection of the  $x$ - $y$ -plane with the  $\omega$ -image of the domain  $\Omega$ . There exist — uniquely determined — angles  $\theta_0 < \theta_1 < \dots < \theta_n < \theta_0 + 2\pi$  such that  $\mu_E$  is constant on each of the sectors  $K_{\theta_j}^{\theta_{j+1}}$  and takes real, symmetric, positive definite  $2 \times 2$  matrices as values. Obviously,  $\mu_E$  and the corresponding two-dimensional div-grad operator  $-\nabla \cdot \rho \nabla$  from Definition 2.1 do not depend on the choice of the point  $P$ . This justifies the following definition of the edge singularity.

**Definition 2.8.** For any of the two-dimensional div-grad operators  $-\nabla \cdot \rho \nabla$  from Definition 2.1 we call the number

$$\delta \stackrel{\text{def}}{=} \inf \{ \Re \lambda : \lambda \text{ is a singular value for the operator } -\nabla \cdot \rho \nabla \}$$

the *vertex singularity*. Now, we assume a constellation as in Definition 2.6, and we define for a three-dimensional div-grad operator with the coefficient matrix-function  $\mu$  the *edge singularity* at  $E$  by the corresponding vertex singularity of the operator  $\nabla \cdot \mu_E \nabla$  on the sector  $K_{\theta_0}^{\theta_n}$ , see [14] and references cited there. If there is a (boundary) neighbourhood of the edge  $E$  belonging to the Neumann boundary part of the three-dimensional problem, then we take  $\nabla \cdot \mu_E \nabla$  with Neumann boundary condition on  $\partial K_{\theta_0}^{\theta_n}$ , see Definition 2.1. This applies mutatis mutandis to a Dirichlet boundary condition.

So, in order to find the edge singularities of a three-dimensional problem as in Definition 2.6, one regards for each edge a two-dimensional problem as in Definition 2.1, and looks for parameters  $\lambda$  such that the operators  $\mathcal{A}_\lambda$ , see Definition 2.3, induced by the two-dimensional problem have a nontrivial kernel, see Definition 2.5.

Our Definition 2.8 of edge singularity corresponds to notions of singularity at edges in physics. For instance, the singularity of the kinetic energy of an acoustic wave at an edge only depends on the opening angle and the material of the edge, see e.g. [63, §5.3.4].

## 2.2 Estimates for the imaginary part of the singularities

We show that the singular values (see Definition 2.5) of the two-dimensional div-grad operators  $-\nabla \cdot \rho \nabla$  from Definition 2.1 lie in a sector of the complex plane. It turns out that this sector is symmetric with respect to the real axis, and its opening angle is explicitly determined by the coefficient matrices  $\rho^j$ ,  $j = 1, \dots, n$ . Actually, we already know from Remark 2.4 that the operator  $\mathcal{A}_\lambda$  is sectorial. In Theorem 2.9 we give now an estimate of the sector containing the singular values. Please note that the angles  $\theta_0, \dots, \theta_n$  do *not* enter into this estimate.

Throughout this section we write the complex number  $\lambda$  in the form  $\lambda = \lambda_1 + i\lambda_2$ .

**Theorem 2.9.** *All values  $\lambda$  from the right half plane, for which the kernel of  $\mathcal{A}_\lambda$ , see Definition 2.3 and Definition 2.5, is nontrivial, are located in the sector*

$$\mathcal{S} \stackrel{\text{def}}{=} \left\{ \lambda_1 + i\lambda_2 : |\lambda_2| \leq \lambda_1 \max_{1 \leq j \leq n} \frac{\text{tr} \rho^j}{2\sqrt{\det \rho^j}} \right\}.$$

*In particular, there are no singular values on the imaginary axis.*

*Proof.* Let us first recall that  $b_2$ , see Definition 2.3, is bounded from below

by a positive constant, see Remark 2.4. Thus, we can estimate

$$\begin{aligned} \Re t_\lambda[\psi] &= \Re \int_{\theta_0}^{\theta_n} b_2 \psi' \overline{\psi'} + \lambda b_1 \psi \overline{\psi'} - \lambda b_1 \psi' \overline{\psi} - \lambda^2 b_0 \psi \overline{\psi} d\theta \\ &\geq \int_{\theta_0}^{\theta_n} b_2 |\psi'|^2 - 2 |\lambda_2| |b_1| |\psi'| |\psi| + (\lambda_2^2 - \lambda_1^2) b_0 |\psi|^2 d\theta \\ &= \int_{\theta_0}^{\theta_n} (\sqrt{b_2} |\psi'| - |\lambda_2| \frac{|b_1|}{\sqrt{b_2}} |\psi|)^2 + (\lambda_2^2 \frac{b_2 b_0 - b_1^2}{b_2} - \lambda_1^2 b_0) |\psi|^2 d\theta. \end{aligned}$$

Using  $b_2 b_0 - b_1^2 = D$ , see (2.4), we can further estimate

$$\geq \int_{\theta_0}^{\theta_n} (\lambda_2^2 \frac{D}{b_2} - \lambda_1^2 b_0) |\psi|^2 d\theta = \int_{\theta_0}^{\theta_n} (\lambda_2^2 - \lambda_1^2 \frac{b_2 b_0}{D}) \frac{D}{b_2} |\psi|^2 d\theta. \quad (2.5)$$

Writing  $b_2 b_0 / D = 1 + b_1^2 / D$  and applying the inequality

$$\begin{aligned} \sup_{\theta \in ]\theta_{j-1}, \theta_j[} |b_1| &= \sup_{\theta \in ]\theta_{j-1}, \theta_j[} \left| \frac{\rho_{22}^j - \rho_{11}^j}{2} \sin 2\theta + \rho_{12}^j \cos 2\theta \right| \\ &\leq \sqrt{\frac{(\rho_{22}^j - \rho_{11}^j)^2}{4} + (\rho_{12}^j)^2} \end{aligned}$$

we may estimate on each interval  $]\theta_{j-1}, \theta_j[$

$$\frac{b_2 b_0}{D} = 1 + \frac{b_1^2}{D} \leq 1 + \frac{(\rho_{22} - \rho_{11})^2 / 4 + \rho_{12}^2}{D} = \frac{(\rho_{11} + \rho_{22})^2}{4D}.$$

Hence, if  $\lambda \notin \mathcal{S}$  and  $\psi \neq 0$ , then (2.5) is strictly positive, thus,  $\ker \mathcal{A}_\lambda$  must be trivial.  $\square$

**Corollary 2.10.** *The singular values (see Definition 2.5) of the two-dimensional div-grad operators  $-\nabla \cdot \rho \nabla$  from Definition 2.1 are uniformly bounded.*

**Remark 2.11.** The term  $\text{tr } \rho^j / \sqrt{4 \det \rho^j}$  does not change its value, when the matrix  $\rho^j$  is multiplied by a positive scalar. Moreover, both the trace and the determinant of a matrix are similarity invariant. Hence, scaling and similarity transformations of the matrices  $\rho^j$ ,  $j = 1, \dots, n$  leave the sector  $\mathcal{S}$  unchanged.

**Remark 2.12.** It would be highly satisfactory to have also an analogous a priori bound for the number of singular values — in terms of the data. Unfortunately, we did not succeed in finding such a bound. For the case of interior edges see [30].

### 2.3 Characterisation of the singularities

Now we want to characterise the edge singularities of the three-dimensional problem, that means in view of Definitions 2.3 and 2.5 the parameters  $\lambda$  such that the operators  $\mathcal{A}_\lambda$  have a nontrivial kernel. We get that all these values  $\lambda$  are roots of a characteristic analytic function.

Standard arguments show that any function  $u$  from the kernel of the operator  $\mathcal{A}_\lambda$ , see Definition 2.3, obeys the differential equation

$$(b_2 u')' + \lambda(b_1 u)' + \lambda b_1 u' + \lambda^2 b_0 u = 0 \quad (2.6)$$

on each of the intervals  $]\theta_{j-1}, \theta_j[$ ,  $j = 1, \dots, n$ , and fulfils, additionally, the transmission conditions

$$[u]_\theta = 0 \quad \text{and} \quad [b_2 u' + \lambda b_1 u]_\theta = 0 \quad (2.7)$$

in every point  $\theta \in \{\theta_1, \dots, \theta_{n-1}\}$ . Here, as usual, we have written

$$[w]_\theta \stackrel{\text{def}}{=} \lim_{\vartheta \downarrow \theta} w(\vartheta) - \lim_{\vartheta \uparrow \theta} w(\vartheta).$$

Following [13] (see also [48, §3.6] for further details) we now regard the elementary solutions

$$\theta \mapsto e^{-i\lambda\theta} (\varsigma e^{2i\theta} + 1)^\lambda, \quad \theta \mapsto e^{i\lambda\theta} (\bar{\varsigma} e^{-2i\theta} + 1)^\lambda$$

of the differential equation (2.6) on each of the intervals  $]\theta_{j-1}, \theta_j[$ . Here, the complex number  $\varsigma = \varsigma_j$  for  $]\theta_{j-1}, \theta_j[$  is determined by

$$\varsigma_j \stackrel{\text{def}}{=} \frac{i(\rho_{22}^j - \sqrt{D_j}) - \rho_{12}^j}{i(\rho_{22}^j + \sqrt{D_j}) + \rho_{12}^j} = \frac{\rho_{22}^j - \rho_{11}^j + 2i\rho_{12}^j}{\rho_{22}^j + \rho_{11}^j + 2\sqrt{D_j}}, \quad (2.8)$$

where  $D_j$  is the determinant of the matrix  $\rho^j$ , see (2.4).

**Remark 2.13.** In the sequel it is important that  $0 \leq |\varsigma_j| < 1$ . This is easily verified using the positivity of  $\rho_{22}^j$ .

**Definition 2.14.** For each material sector  $K_{\theta_{j-1}}^{\theta_j}$  we now define the *characteristic angle of anisotropy* by

$$\kappa_j \stackrel{\text{def}}{=} \arg \frac{\bar{\varsigma}_j e^{-2i\theta_j} + 1}{\bar{\varsigma}_j e^{-2i\theta_{j-1}} + 1}, \quad j = 1, \dots, n. \quad (2.9)$$

By (2.1) we have  $-\pi < \kappa_j \leq \pi$ .

**Remark 2.15.** If the material in the sector  $K_{\theta_{j-1}}^{\theta_j}$  is isotropic, that means, if  $\rho^j$  is a positive multiple of the identity matrix, then  $\varsigma_j$  is zero and a fortiori  $\kappa_j$  vanishes. The anisotropy of the material enters our considerations as a shift of the sector's opening angle  $\theta_j - \theta_{j-1}$  by  $\kappa_j$ , that means the “material” opening angle of the sector is  $\theta_j - \theta_{j-1} + \kappa_j$ .

On each interval  $]\theta_{j-1}, \theta_j[$  the ansatz functions

$$u_j(\theta) \stackrel{\text{def}}{=} \hat{c}_j e^{-i\lambda\theta} (\varsigma_j e^{2i\theta} + 1)^\lambda + \check{c}_j e^{i\lambda\theta} (\bar{\varsigma}_j e^{-2i\theta} + 1)^\lambda \quad (2.10)$$

satisfy (2.6), see [13], also compare [48, §3.6]. The transmission conditions (2.7) at  $\theta_1, \dots, \theta_{n-1}$  together with either the boundary conditions at  $\theta_0$  and  $\theta_n$  lead to a  $2n \times 2n$  homogeneous linear system for the coefficients  $\hat{c}_j, \check{c}_j$ . The determinant of this matrix is an analytic function in  $\lambda$  — the characteristic function of the edge under consideration. The zeros of this function provide all the values of  $\lambda$  for which the problem (2.6) with (2.7) has a nontrivial solution, thus,  $\mathcal{A}_\lambda$  has a nontrivial kernel.

In our setup of the transcendental equation for the singular values  $\lambda$ , we need the following reformulation of the boundary conditions, and of the transmission conditions.

**Proposition 2.16.** *See [24, Lemma 20 and Corollary 21]. Let  $u$  be the function on  $[\theta_0, \theta_n]$  which coincides on  $]\theta_{j-1}, \theta_j[$ ,  $j = 1, \dots, n$ , with  $u_j$  as defined in (2.10).*

1. For  $\lambda \neq 0$  Neumann boundary conditions

$$(b_2 u' + \lambda b_1 u)|_{\theta=\theta_0} = 0, \quad (b_2 u' + \lambda b_1 u)|_{\theta=\theta_n} = 0$$

equivalently can be expressed as

$$\begin{aligned} \hat{c}_1 e^{-i\lambda\theta_0} (\varsigma_1 e^{2i\theta_0} + 1)^\lambda &= \check{c}_1 e^{i\lambda\theta_0} (\bar{\varsigma}_1 e^{-2i\theta_0} + 1)^\lambda, \\ \hat{c}_n e^{-i\lambda\theta_n} (\varsigma_n e^{2i\theta_n} + 1)^\lambda &= \check{c}_n e^{i\lambda\theta_n} (\bar{\varsigma}_n e^{-2i\theta_n} + 1)^\lambda. \end{aligned}$$

2. For  $\lambda \neq 0$  the transmission conditions (2.7) at a point  $\theta = \theta_j$ ,  $j = 1, \dots, n-1$ , for the function  $u$  equivalently can be expressed as

$$\begin{aligned} \hat{c}_j e^{-i\lambda\theta} (\varsigma_j e^{2i\theta} + 1)^\lambda + \check{c}_j e^{i\lambda\theta} (\bar{\varsigma}_j e^{-2i\theta} + 1)^\lambda \\ = \hat{c}_{j+1} e^{-i\lambda\theta} (\varsigma_{j+1} e^{2i\theta} + 1)^\lambda + \check{c}_{j+1} e^{i\lambda\theta} (\bar{\varsigma}_{j+1} e^{-2i\theta} + 1)^\lambda \end{aligned} \quad (2.11)$$

and

$$\begin{aligned} \sqrt{D_j} (\hat{c}_j e^{-i\lambda\theta} (\varsigma_j e^{2i\theta} + 1)^\lambda - \check{c}_j e^{i\lambda\theta} (\bar{\varsigma}_j e^{-2i\theta} + 1)^\lambda) \\ = \sqrt{D_{j+1}} (\hat{c}_{j+1} e^{-i\lambda\theta} (\varsigma_{j+1} e^{2i\theta} + 1)^\lambda - \check{c}_{j+1} e^{i\lambda\theta} (\bar{\varsigma}_{j+1} e^{-2i\theta} + 1)^\lambda), \end{aligned} \quad (2.12)$$

respectively.

The next lemma justifies an algebraic manipulation which will be frequently used in the treatment of the boundary and transmission conditions.

**Lemma 2.17.** *Let us regard numbers  $\chi \in \mathbb{C}$  with  $|\chi| < 1$ ,  $\zeta \in ]0, 2\pi]$  and  $\lambda \in \mathbb{C}$  with  $0 < \Re\lambda < 1$ . Then*

$$\frac{(\chi e^{-2i\zeta} + 1)^\lambda}{(\chi + 1)^\lambda} \frac{(\bar{\chi} + 1)^\lambda}{(\bar{\chi} e^{2i\zeta} + 1)^\lambda} = \left( \frac{\chi e^{-2i\zeta} + 1}{\chi + 1} \right)^\lambda \left( \frac{\bar{\chi} + 1}{\bar{\chi} e^{2i\zeta} + 1} \right)^\lambda = e^{2i\lambda\kappa}, \quad (2.13)$$

where

$$\kappa = \arg \frac{\chi e^{-2i\zeta} + 1}{\chi + 1} \in ]-\pi, \pi].$$

Moreover, the values  $\zeta$  and  $\kappa$  are related in the following way (see [24, Lemma 26]):

$$\text{Either } \zeta, \zeta + \kappa \in ]0, \pi[ \text{ or } \zeta = \zeta + \kappa = \pi \text{ or } \zeta, \zeta + \kappa \in ]\pi, 2\pi[.$$

*Proof.* We first prove (2.13). Due to  $|\chi| < 1$ , all the terms  $\chi e^{-2i\zeta} + 1$ ,  $\chi + 1$ ,  $\bar{\chi} + 1$ ,  $\bar{\chi} e^{2i\zeta} + 1$  have positive real part. Thus, the first equality follows from our definition (2.1) of the power function, and the supposition  $\Re\lambda \in ]0, 1[$ . On the other hand, one has

$$\frac{\bar{\chi} + 1}{\bar{\chi} e^{2i\zeta} + 1} = \overline{\left( \frac{\chi e^{-2i\zeta} + 1}{\chi + 1} \right)^{-1}}.$$

This, together with (2.1), and the definition of  $\kappa$ , yields the second equality.

We now prove the second assertion. If  $\zeta = \pi$ , then by definition  $\kappa = 0$ . Also from the definition of  $\kappa$  we have a priori  $\zeta + \kappa \in ]-\pi, 2\pi[$  for  $\zeta \in ]0, \pi[$ , and  $\zeta + \kappa \in ]0, 3\pi[$  for  $\zeta \in ]\pi, 2\pi[$ . Moreover, for  $\zeta \in ]0, 2\pi[ \setminus \{\pi\}$  one has

$$\begin{aligned} e^{i(\zeta+\kappa)} &= e^{i\zeta} \frac{\chi e^{-2i\zeta} + 1}{\chi + 1} \frac{|\chi + 1|}{|\chi e^{-2i\zeta} + 1|} = \frac{(\chi e^{-i\zeta} + e^{i\zeta})(\bar{\chi} + 1)}{|\chi + 1| |\chi e^{-2i\zeta} + 1|} \\ &= \frac{|\chi|^2 e^{-i\zeta} + e^{i\zeta} + 2\Re(\chi e^{-i\zeta})}{|\chi + 1| |\chi e^{-2i\zeta} + 1|}. \end{aligned} \quad (2.14)$$

Thus,

$$\Im e^{i(\zeta+\kappa)} = \frac{(1 - |\chi|^2) \sin \zeta}{|\chi + 1| |\chi e^{-2i\zeta} + 1|}$$

and the sign of  $\Im e^{i(\zeta+\kappa)}$  only depends on  $\zeta$ . □

If we specify in Lemma 2.17

$$\chi = \bar{\zeta}_j e^{-2i\theta_{j-1}} \quad \text{and} \quad \zeta = \theta_j - \theta_{j-1}, \quad j = 1, \dots, n,$$

see Definition 2.1 and (2.8), then we get the following corollary.



**Corollary 2.18.** *For the numbers  $\theta_j$ ,  $\varsigma_j$ , and  $\kappa_j$ , see Definition 2.1, (2.8), and (2.9), respectively, holds true*

$$\frac{(\bar{\varsigma}_j e^{-2i\theta_j} + 1)^\lambda (\varsigma_j e^{2i\theta_{j-1}} + 1)^\lambda}{(\bar{\varsigma}_j e^{-2i\theta_{j-1}} + 1)^\lambda (\varsigma_j e^{2i\theta_j} + 1)^\lambda} = e^{2i\lambda\kappa_j}, \quad j = 1, \dots, n,$$

for all  $\lambda \in \mathbb{C}$  with  $0 < \Re\lambda < 1$ . Moreover,

$$\begin{aligned} \theta_j - \theta_{j-1} \in ]0, \pi[ & \text{ iff } \theta_j - \theta_{j-1} + \kappa_j \in ]0, \pi[, \\ \theta_j - \theta_{j-1} = \pi & \text{ iff } \theta_j - \theta_{j-1} + \kappa_j = \pi, \\ \theta_j - \theta_{j-1} \in ]\pi, 2\pi[ & \text{ iff } \theta_j - \theta_{j-1} + \kappa_j \in ]\pi, 2\pi[. \end{aligned} \quad (2.15)$$

Hence, for two adjacent sectors  $K_{\theta_{j-2}}^{\theta_{j-1}}$  and  $K_{\theta_{j-1}}^{\theta_j}$  we have

$$0 < \theta_j - \theta_{j-2} + \kappa_j + \kappa_{j-1} < 2\pi \quad (2.16)$$

if both opening angles are smaller than  $\pi$ , or

$$\pi < \theta_j - \theta_{j-2} + \kappa_j + \kappa_{j-1} < 2\pi \quad (2.17)$$

if one opening angle is  $\pi$ , or

$$\pi < \theta_j - \theta_{j-2} + \kappa_j + \kappa_{j-1} < 3\pi \quad (2.18)$$

if one opening angle is greater or equal  $\pi$ . Nota bene, all but one of the opening angles must be smaller than  $\pi$ .

## 2.4 The characteristic equation for four materials

From now on we specialise to the case of just four materials meeting at an edge on the boundary of the three-dimensional domain  $\Omega$ , see Definition 2.6. More precisely, we regard a constellation as in Definition 2.1 and Figure 3 with angles  $\theta_0 < \dots < \theta_4 < \theta_0 + 2\pi$ , and Dirichlet or Neumann boundary conditions. With respect to this constellation, and the corresponding anisotropy shifts (2.9) we define the complex valued functions  $F_N$ ,  $G_N$ ,  $F_D$ ,  $G_D$  on  $\mathbb{C}$  by

$$\begin{aligned} F_N(\lambda) &\stackrel{\text{def}}{=} e^{i\lambda(\theta_2 - \theta_0 + \kappa_1 + \kappa_2)} \left(1 - \frac{\sqrt{D_1} - \sqrt{D_2}}{\sqrt{D_1} + \sqrt{D_2}} e^{-2i\lambda(\theta_1 - \theta_0 + \kappa_1)}\right), \\ G_N(\lambda) &\stackrel{\text{def}}{=} e^{i\lambda(\theta_4 - \theta_2 + \kappa_3 + \kappa_4)} \left(1 + \frac{\sqrt{D_3} - \sqrt{D_4}}{\sqrt{D_3} + \sqrt{D_4}} e^{-2i\lambda(\theta_4 - \theta_3 + \kappa_4)}\right), \\ F_D(\lambda) &\stackrel{\text{def}}{=} e^{i\lambda(\theta_2 - \theta_0 + \kappa_1 + \kappa_2)} \left(1 + \frac{\sqrt{D_1} - \sqrt{D_2}}{\sqrt{D_1} + \sqrt{D_2}} e^{-2i\lambda(\theta_1 - \theta_0 + \kappa_1)}\right), \\ G_D(\lambda) &\stackrel{\text{def}}{=} e^{i\lambda(\theta_4 - \theta_2 + \kappa_3 + \kappa_4)} \left(1 - \frac{\sqrt{D_3} - \sqrt{D_4}}{\sqrt{D_3} + \sqrt{D_4}} e^{-2i\lambda(\theta_4 - \theta_3 + \kappa_4)}\right). \end{aligned}$$

Referring to Definition 2.1 and Definition 2.5 we now can state our main theorem.

**Theorem 2.19.** *The singular values  $\lambda$  of the operator  $-\nabla \cdot \rho \nabla$  with Neumann boundary conditions are the solutions of the equation*

$$\begin{aligned} & \sqrt{D_3}(F_N(\lambda) + F_N(-\lambda)) (G_N(\lambda) - G_N(-\lambda)) \\ & + \sqrt{D_2}(F_N(\lambda) - F_N(-\lambda)) (G_N(\lambda) + G_N(-\lambda)) = 0. \end{aligned} \quad (2.19)$$

*The singular values  $\lambda$  of the operator  $-\nabla \cdot \rho \nabla$  with Dirichlet boundary conditions are the solutions of the equation*

$$\begin{aligned} & \sqrt{D_3}(F_D(\lambda) - F_D(-\lambda)) (G_D(\lambda) + G_D(-\lambda)) \\ & + \sqrt{D_2}(G_D(\lambda) - G_D(-\lambda)) (F_D(\lambda) + F_D(-\lambda)) = 0. \end{aligned} \quad (2.20)$$

**Remark 2.20.** The left hand sides of (2.19) and (2.20) are entire functions in  $\lambda$ . We already know, see Corollary 2.10, that the imaginary parts of the singular values are uniformly bounded, and the real parts of the singular values are bounded by Definition 2.5. Hence, Theorem 2.19 implies that if there are singular values at all, then there is a singular value  $\lambda_0$  such that  $\mathfrak{I}\lambda_0 = 0$ , see Definition 2.8.

*Proof of Theorem 2.19.* We prove only the case of Neumann boundary conditions explicitly. The case of Dirichlet boundary conditions requires only obvious modifications pointed out at the end of the proof.

Let us introduce two more complex valued functions on  $\mathbb{C}$  by

$$\begin{aligned} X_N(\lambda) & \stackrel{\text{def}}{=} e^{-i\lambda(\theta_2 - \theta_0 + \kappa_1 + \kappa_2)} F_N(\lambda) = 1 - \frac{\sqrt{D_1} - \sqrt{D_2}}{\sqrt{D_1} + \sqrt{D_2}} e^{-2i\lambda(\theta_1 - \theta_0 + \kappa_1)} \\ Y_N(\lambda) & \stackrel{\text{def}}{=} e^{-i\lambda(\theta_4 - \theta_2 + \kappa_3 + \kappa_4)} G_N(\lambda) = 1 + \frac{\sqrt{D_3} - \sqrt{D_4}}{\sqrt{D_3} + \sqrt{D_4}} e^{-2i\lambda(\theta_4 - \theta_3 + \kappa_4)} \end{aligned} \quad (2.21)$$

We first prove that (2.19) is a necessary condition for  $\lambda$  to be a singular value. According to the first part of Proposition 2.16 the Neumann boundary conditions for the ansatz functions (2.10) in  $\theta_0$  and  $\theta_4$  provide

$$\check{c}_1 = e^{-2i\lambda\theta_0} \frac{(\varsigma_1 e^{2i\theta_0} + 1)^\lambda}{(\bar{\varsigma}_1 e^{-2i\theta_0} + 1)^\lambda} \hat{c}_1, \quad \check{c}_4 = e^{2i\lambda\theta_4} \frac{(\bar{\varsigma}_4 e^{-2i\theta_4} + 1)^\lambda}{(\varsigma_4 e^{2i\theta_4} + 1)^\lambda} \hat{c}_4. \quad (2.22)$$

Note that the denominators do not vanish thanks to Remark 2.13.

We now establish further relations between the coefficients of the ansatz functions (2.10) by means of the transmission conditions (2.7) in  $\theta_1$ ,  $\theta_2$  and  $\theta_3$ , that means at the interior material interfaces. First, it is clear from the second part of Proposition 2.16, that, if at least one of the constants  $\hat{c}_1$ ,  $\check{c}_1$ ,  $\hat{c}_4$ ,  $\check{c}_4$  vanishes, then the others and, additionally,  $\hat{c}_2$ ,  $\check{c}_2$ ,  $\hat{c}_3$ ,  $\check{c}_3$  also vanish. Making use of (2.11) and (2.12) in  $\theta_1$  we further get

$$\begin{aligned} 2\hat{c}_2(\varsigma_2 e^{2i\theta_1} + 1)^\lambda & = \hat{c}_1 \left(1 + \frac{\sqrt{D_1}}{\sqrt{D_2}}\right) (\varsigma_1 e^{2i\theta_1} + 1)^\lambda \\ & + \check{c}_1 \left(1 - \frac{\sqrt{D_1}}{\sqrt{D_2}}\right) e^{2i\lambda\theta_1} (\bar{\varsigma}_1 e^{-2i\theta_1} + 1)^\lambda, \end{aligned} \quad (2.23)$$

$$\begin{aligned}
2\check{c}_2(\bar{\varsigma}_2 e^{-2i\theta_1} + 1)^\lambda &= \hat{c}_1 \left(1 - \frac{\sqrt{D_1}}{\sqrt{D_2}}\right) e^{-2i\lambda\theta_1} (\varsigma_1 e^{2i\theta_1} + 1)^\lambda \\
&\quad + \check{c}_1 \left(1 + \frac{\sqrt{D_1}}{\sqrt{D_2}}\right) (\bar{\varsigma}_1 e^{-2i\theta_1} + 1)^\lambda.
\end{aligned} \tag{2.24}$$

Replacing  $\check{c}_1$  by means of (2.22) yields

$$\begin{aligned}
\hat{c}_2 &= \frac{\hat{c}_1 (\varsigma_1 e^{2i\theta_1} + 1)^\lambda}{2(\varsigma_2 e^{2i\theta_1} + 1)^\lambda} \left( \left(1 + \frac{\sqrt{D_1}}{\sqrt{D_2}}\right) \right. \\
&\quad \left. + \left(1 - \frac{\sqrt{D_1}}{\sqrt{D_2}}\right) e^{2i\lambda(\theta_1 - \theta_0)} \frac{(\bar{\varsigma}_1 e^{-2i\theta_1} + 1)^\lambda (\varsigma_1 e^{2i\theta_0} + 1)^\lambda}{(\bar{\varsigma}_1 e^{-2i\theta_0} + 1)^\lambda (\varsigma_1 e^{2i\theta_1} + 1)^\lambda} \right)
\end{aligned}$$

and

$$\begin{aligned}
\check{c}_2 &= \frac{\hat{c}_1 (\varsigma_1 e^{2i\theta_1} + 1)^\lambda}{2(\bar{\varsigma}_2 e^{-2i\theta_1} + 1)^\lambda} \left( \left(1 - \frac{\sqrt{D_1}}{\sqrt{D_2}}\right) e^{-2i\lambda\theta_1} \right. \\
&\quad \left. + \left(1 + \frac{\sqrt{D_1}}{\sqrt{D_2}}\right) e^{-2i\lambda\theta_0} \frac{(\bar{\varsigma}_1 e^{-2i\theta_1} + 1)^\lambda (\varsigma_1 e^{2i\theta_0} + 1)^\lambda}{(\bar{\varsigma}_1 e^{-2i\theta_0} + 1)^\lambda (\varsigma_1 e^{2i\theta_1} + 1)^\lambda} \right).
\end{aligned}$$

We now apply Corollary 2.18. Thus, we get with (2.21)

$$\begin{aligned}
\hat{c}_2 &= \hat{c}_1 \frac{(\varsigma_1 e^{2i\theta_1} + 1)^\lambda}{2(\varsigma_2 e^{2i\theta_1} + 1)^\lambda} \left( \left(1 + \frac{\sqrt{D_1}}{\sqrt{D_2}}\right) + \left(1 - \frac{\sqrt{D_1}}{\sqrt{D_2}}\right) e^{2i\lambda(\theta_1 - \theta_0 + \kappa_1)} \right) \\
&= \hat{c}_1 \frac{(\varsigma_1 e^{2i\theta_1} + 1)^\lambda}{2(\varsigma_2 e^{2i\theta_1} + 1)^\lambda} \frac{\sqrt{D_1 + \sqrt{D_2}}}{\sqrt{D_2}} X_N(-\lambda)
\end{aligned} \tag{2.25}$$

and

$$\begin{aligned}
\check{c}_2 &= \hat{c}_1 \frac{(\varsigma_1 e^{2i\theta_1} + 1)^\lambda}{2(\bar{\varsigma}_2 e^{-2i\theta_1} + 1)^\lambda} e^{2i\lambda(\kappa_1 - \theta_0)} \left( \left(1 + \frac{\sqrt{D_1}}{\sqrt{D_2}}\right) + \left(1 - \frac{\sqrt{D_1}}{\sqrt{D_2}}\right) e^{-2i\lambda(\theta_1 - \theta_0 + \kappa_1)} \right) \\
&= \hat{c}_1 \frac{(\varsigma_1 e^{2i\theta_1} + 1)^\lambda}{2(\bar{\varsigma}_2 e^{-2i\theta_1} + 1)^\lambda} e^{2i\lambda(\kappa_1 - \theta_0)} \frac{\sqrt{D_1 + \sqrt{D_2}}}{\sqrt{D_2}} X_N(\lambda).
\end{aligned} \tag{2.26}$$

Analogously, the transmission conditions in the form (2.11) and (2.12) at  $\theta_3$  first lead to

$$\begin{aligned}
2\hat{c}_3(\varsigma_3 e^{2i\theta_3} + 1)^\lambda &= \hat{c}_4 \left(1 + \frac{\sqrt{D_4}}{\sqrt{D_3}}\right) (\varsigma_4 e^{2i\theta_3} + 1)^\lambda \\
&\quad + \check{c}_4 \left(1 - \frac{\sqrt{D_4}}{\sqrt{D_3}}\right) e^{2i\lambda\theta_3} (\bar{\varsigma}_4 e^{-2i\theta_3} + 1)^\lambda,
\end{aligned} \tag{2.27}$$

$$\begin{aligned}
2\check{c}_3(\bar{\varsigma}_3 e^{-2i\theta_3} + 1)^\lambda &= \hat{c}_4 \left(1 - \frac{\sqrt{D_4}}{\sqrt{D_3}}\right) e^{-2i\lambda\theta_3} (\varsigma_4 e^{2i\theta_3} + 1)^\lambda \\
&\quad + \check{c}_4 \left(1 + \frac{\sqrt{D_4}}{\sqrt{D_3}}\right) (\bar{\varsigma}_4 e^{-2i\theta_3} + 1)^\lambda.
\end{aligned} \tag{2.28}$$

Replacing  $\hat{c}_4$  by means of (2.22) and making use of Corollary 2.18 we get with (2.21)

$$\begin{aligned}\hat{c}_3 &= \check{c}_4 \frac{(\bar{\varsigma}_4 e^{-2i\theta_3} + 1)^\lambda}{2(\varsigma_3 e^{2i\theta_3} + 1)^\lambda} e^{2i\lambda(\theta_4 + \kappa_4)} \left( \left(1 + \frac{\sqrt{D_4}}{\sqrt{D_3}}\right) + \left(1 - \frac{\sqrt{D_4}}{\sqrt{D_3}}\right) e^{-2i\lambda(\theta_4 - \theta_3 + \kappa_4)} \right) \\ &= \check{c}_4 \frac{(\bar{\varsigma}_4 e^{-2i\theta_3} + 1)^\lambda}{2(\varsigma_3 e^{2i\theta_3} + 1)^\lambda} e^{2i\lambda(\theta_4 + \kappa_4)} \frac{\sqrt{D_3} + \sqrt{D_4}}{\sqrt{D_3}} Y_N(\lambda)\end{aligned}\quad (2.29)$$

and

$$\begin{aligned}\check{c}_3 &= \check{c}_4 \frac{(\bar{\varsigma}_4 e^{-2i\theta_3} + 1)^\lambda}{2(\bar{\varsigma}_3 e^{-2i\theta_3} + 1)^\lambda} \left( \left(1 + \frac{\sqrt{D_4}}{\sqrt{D_3}}\right) + \left(1 - \frac{\sqrt{D_4}}{\sqrt{D_3}}\right) e^{2i\lambda(\theta_4 - \theta_3 + \kappa_4)} \right) \\ &= \check{c}_4 \frac{(\bar{\varsigma}_4 e^{-2i\theta_3} + 1)^\lambda}{2(\bar{\varsigma}_3 e^{-2i\theta_3} + 1)^\lambda} \frac{\sqrt{D_3} + \sqrt{D_4}}{\sqrt{D_3}} Y_N(-\lambda).\end{aligned}\quad (2.30)$$

The transmission conditions in  $\theta_2$  written according to the second part of Proposition 2.16 are

$$\begin{aligned}\hat{c}_2 e^{-i\lambda\theta_2} (\varsigma_2 e^{2i\theta_2} + 1)^\lambda + \check{c}_2 e^{i\lambda\theta_2} (\bar{\varsigma}_2 e^{-2i\theta_2} + 1)^\lambda \\ = \hat{c}_3 e^{-i\lambda\theta_2} (\varsigma_3 e^{2i\theta_2} + 1)^\lambda + \check{c}_3 e^{i\lambda\theta_2} (\bar{\varsigma}_3 e^{-2i\theta_2} + 1)^\lambda\end{aligned}\quad (2.31)$$

and

$$\begin{aligned}\sqrt{D_2} (\hat{c}_2 e^{-i\lambda\theta_2} (\varsigma_2 e^{2i\theta_2} + 1)^\lambda - \check{c}_2 e^{i\lambda\theta_2} (\bar{\varsigma}_2 e^{-2i\theta_2} + 1)^\lambda) \\ = \sqrt{D_3} (\hat{c}_3 e^{-i\lambda\theta_2} (\varsigma_3 e^{2i\theta_2} + 1)^\lambda - \check{c}_3 e^{i\lambda\theta_2} (\bar{\varsigma}_3 e^{-2i\theta_2} + 1)^\lambda).\end{aligned}\quad (2.32)$$

Here we replace  $\hat{c}_2$ ,  $\check{c}_2$ ,  $\hat{c}_3$ , and  $\check{c}_3$  by means of (2.25), (2.26), (2.29), and (2.30), respectively, and get

$$\begin{aligned}\hat{c}_1 \frac{\sqrt{D_1} + \sqrt{D_2}}{\sqrt{D_2}} (\varsigma_1 e^{2i\theta_1} + 1)^\lambda \left( \frac{(\varsigma_2 e^{2i\theta_2} + 1)^\lambda}{(\varsigma_2 e^{2i\theta_1} + 1)^\lambda} X_N(-\lambda) e^{-i\lambda\theta_2} \right. \\ \left. + \frac{(\bar{\varsigma}_2 e^{-2i\theta_2} + 1)^\lambda}{(\bar{\varsigma}_2 e^{-2i\theta_1} + 1)^\lambda} e^{2i\lambda(\kappa_1 - \theta_0)} X_N(\lambda) e^{i\lambda\theta_2} \right) \\ = \check{c}_4 \frac{\sqrt{D_3} + \sqrt{D_4}}{\sqrt{D_3}} (\bar{\varsigma}_4 e^{-2i\theta_3} + 1)^\lambda \left( \frac{(\varsigma_3 e^{2i\theta_2} + 1)^\lambda}{(\varsigma_3 e^{2i\theta_3} + 1)^\lambda} e^{2i\lambda(\theta_4 + \kappa_4)} Y_N(\lambda) e^{-i\lambda\theta_2} \right. \\ \left. + \frac{(\bar{\varsigma}_3 e^{-2i\theta_2} + 1)^\lambda}{(\bar{\varsigma}_3 e^{-2i\theta_3} + 1)^\lambda} Y_N(-\lambda) e^{i\lambda\theta_2} \right)\end{aligned}\quad (2.33)$$

and

$$\begin{aligned}
& \hat{c}_1(\sqrt{D_1} + \sqrt{D_2})(\varsigma_1 e^{2i\theta_1} + 1)^\lambda \left( \frac{(\varsigma_2 e^{2i\theta_2} + 1)^\lambda}{(\varsigma_2 e^{2i\theta_1} + 1)^\lambda} X_N(-\lambda) e^{-i\lambda\theta_2} \right. \\
& \quad \left. - \frac{(\bar{\varsigma}_2 e^{-2i\theta_2} + 1)^\lambda}{(\bar{\varsigma}_2 e^{-2i\theta_1} + 1)^\lambda} e^{2i\lambda(\kappa_1 - \theta_0)} X_N(\lambda) e^{i\lambda\theta_2} \right) \\
& = \check{c}_4(\sqrt{D_3} + \sqrt{D_4})(\bar{\varsigma}_4 e^{-2i\theta_3} + 1)^\lambda \left( \frac{(\varsigma_3 e^{2i\theta_2} + 1)^\lambda}{(\varsigma_3 e^{2i\theta_3} + 1)^\lambda} e^{2i\lambda(\theta_4 + \kappa_4)} Y_N(\lambda) e^{-i\lambda\theta_2} \right. \\
& \quad \left. - \frac{(\bar{\varsigma}_3 e^{-2i\theta_2} + 1)^\lambda}{(\bar{\varsigma}_3 e^{-2i\theta_3} + 1)^\lambda} Y_N(-\lambda) e^{i\lambda\theta_2} \right). \quad (2.34)
\end{aligned}$$

This system is non-trivially solvable in  $\hat{c}_1, \check{c}_4$  iff

$$\begin{aligned}
0 & = \sqrt{D_3} \left( X_N(-\lambda) + e^{2i\lambda(\theta_2 - \theta_0 + \kappa_1)} X_N(\lambda) \frac{(\bar{\varsigma}_2 e^{-2i\theta_2} + 1)^\lambda (\varsigma_2 e^{2i\theta_1} + 1)^\lambda}{(\bar{\varsigma}_2 e^{-2i\theta_1} + 1)^\lambda (\varsigma_2 e^{2i\theta_2} + 1)^\lambda} \right) \times \\
& \quad \times \left( Y_N(-\lambda) - e^{2i\lambda(\theta_4 - \theta_2 + \kappa_4)} Y_N(\lambda) \frac{(\bar{\varsigma}_3 e^{-2i\theta_3} + 1)^\lambda (\varsigma_3 e^{2i\theta_2} + 1)^\lambda}{(\bar{\varsigma}_3 e^{-2i\theta_2} + 1)^\lambda (\varsigma_3 e^{2i\theta_3} + 1)^\lambda} \right) \\
& + \sqrt{D_2} \left( X_N(-\lambda) - e^{2i\lambda(\kappa_1 + \theta_2 - \theta_0)} X_N(\lambda) \frac{(\bar{\varsigma}_2 e^{-2i\theta_2} + 1)^\lambda (\varsigma_2 e^{2i\theta_1} + 1)^\lambda}{(\bar{\varsigma}_2 e^{-2i\theta_1} + 1)^\lambda (\varsigma_2 e^{2i\theta_2} + 1)^\lambda} \right) \times \\
& \quad \times \left( e^{2i\lambda(\theta_4 - \theta_2 + \kappa_4)} Y_N(\lambda) \frac{(\bar{\varsigma}_3 e^{-2i\theta_3} + 1)^\lambda (\varsigma_3 e^{2i\theta_2} + 1)^\lambda}{(\bar{\varsigma}_3 e^{-2i\theta_2} + 1)^\lambda (\varsigma_3 e^{2i\theta_3} + 1)^\lambda} + Y_N(-\lambda) \right).
\end{aligned}$$

Making use of Corollary 2.18 one ends up with

$$\begin{aligned}
& \sqrt{D_3} \left( e^{2i\lambda(\theta_2 - \theta_0 + \kappa_1 + \kappa_2)} X_N(\lambda) + X_N(-\lambda) \right) \left( e^{2i\lambda(\theta_4 - \theta_2 + \kappa_3 + \kappa_4)} Y_N(\lambda) - Y_N(-\lambda) \right) \\
& \quad + \sqrt{D_2} \left( e^{2i\lambda(\theta_2 - \theta_0 + \kappa_1 + \kappa_2)} X_N(\lambda) - X_N(-\lambda) \right) \times \\
& \quad \times \left( e^{2i\lambda(\theta_4 - \theta_2 + \kappa_3 + \kappa_4)} Y_N(\lambda) + Y_N(-\lambda) \right) = 0,
\end{aligned}$$

which yields (2.19).

We proceed by showing that (2.19) is sufficient for  $\lambda$  to be a singular value. By the preceding considerations it is clear that (2.19) implies the nontrivial solvability of the linear system (2.33)-(2.34) in  $\hat{c}_1$  and  $\check{c}_4$ . Let now  $\hat{c}_1, \check{c}_4$  be any (nontrivial) solution of this system. If one defines  $\check{c}_1, \hat{c}_4$  by (2.22), then the Neumann boundary conditions are fulfilled. Further, if one defines  $\hat{c}_2, \check{c}_2$  by (2.23)-(2.24), then the transmission conditions in  $\theta_1$  are satisfied. Analogously, the transmission conditions in  $\theta_3$  are satisfied if one defines  $\hat{c}_3, \check{c}_3$  by (2.27)-(2.28). With  $\check{c}_1, \hat{c}_2, \check{c}_2, \hat{c}_3, \check{c}_3, \hat{c}_4$  thus specified, (2.33)-(2.34) are equivalent to the transmission conditions (2.31)-(2.32).

Let us now turn to the case of Dirichlet boundary conditions. These conditions for the ansatz functions (2.10) in  $\theta_0$  and  $\theta_4$  provide

$$\check{c}_1 = -e^{-2i\lambda\theta_0} \frac{(\varsigma_1 e^{2i\theta_0} + 1)^\lambda}{(\bar{\varsigma}_1 e^{-2i\theta_0} + 1)^\lambda} \hat{c}_1 \quad \text{and} \quad \hat{c}_4 = -e^{2i\lambda\theta_4} \frac{(\bar{\varsigma}_4 e^{-2i\theta_4} + 1)^\lambda}{(\varsigma_4 e^{2i\theta_4} + 1)^\lambda} \check{c}_4, \quad (2.35)$$

respectively. If one replaces  $\check{c}_1$  in (2.23)-(2.24) and  $\hat{c}_4$  in (2.27)-(2.28) according to (2.35) and then proceeds as in the Neumann case, one ends up with the condition (2.20).  $\square$

### 3 Bounds for the singular values

Here we consider special cases of the constellation from Definition 2.1 treated in Section 2. We aim at tightening the estimates from Section 2.2. First, as in Section 2.4, we consider the case of four materials, and assume that for two adjacent sectors  $K_{\theta_{j-1}}^{\theta_j}$  and  $K_{\theta_j}^{\theta_{j+1}}$  the determinants of the corresponding coefficient matrices are equal:  $D_j = D_{j+1}$ . Second, we deal with the three-material case as a specialisation of the four-material configuration from Section 2.4 by supposing that the coefficient matrices  $\rho^3$  and  $\rho^4$  are equal, thus, considering the two sectors  $K_{\theta_2}^{\theta_3}$  and  $K_{\theta_3}^{\theta_4}$  as one single-material sector.

#### 3.1 Four materials and a determinant condition

We regard the four-material constellation of Section 2.4. Additionally, for two adjacent sectors the determinants of the corresponding coefficient matrices shall be equal. Without loss of generality we assume that the determinants of the coefficient matrices  $\rho^3$  and  $\rho^4$  are equal. We use the notation of Definition 2.1 and Definition 2.3.

**Theorem 3.1.** *If in the constellation of Definition 2.1 with  $n = 4$  the material determinants  $D_3$  and  $D_4$ , see (2.4), are equal, then for the singular values of Definition 2.5 holds true:*

1. Every singular value  $\lambda$  which is not

$$\lambda = \frac{k\pi}{\theta_4 - \theta_2 + \kappa_3 + \kappa_4}, \quad k = 1, 2, \quad (3.1)$$

satisfies the equation

$$i\sqrt{D_3}(F_N(\lambda) + F_N(-\lambda)) + \sqrt{D_2}(F_N(\lambda) - F_N(-\lambda)) \cot(\lambda(\theta_4 - \theta_2 + \kappa_3 + \kappa_4)) = 0 \quad (3.2)$$

in the case of Neumann boundary conditions, and the equation

$$\begin{aligned} \sqrt{D_3}(F_D(\lambda) - F_D(-\lambda)) \cot(\lambda(\theta_4 - \theta_2 + \kappa_3 + \kappa_4)) \\ + i\sqrt{D_2}(F_D(\lambda) + F_D(-\lambda)) = 0 \end{aligned} \quad (3.3)$$

in the case of Dirichlet boundary conditions.

2. Suppose, additionally,  $D_1 = D_2$ . Then, every singular value  $\lambda$  which is not (3.1) or

$$\lambda = \frac{k\pi}{\theta_2 - \theta_0 + \kappa_1 + \kappa_2}, \quad k = 1, 2, \quad (3.4)$$

satisfies the equation

$$\sqrt{D_3} \cot(\lambda(\theta_2 - \theta_0 + \kappa_1 + \kappa_2)) + \sqrt{D_2} \cot(\lambda(\theta_4 - \theta_2 + \kappa_3 + \kappa_4)) = 0 \quad (3.5)$$

in the case of Neumann boundary conditions, and the equation

$$\sqrt{D_2} \cot(\lambda(\theta_2 - \theta_0 + \kappa_1 + \kappa_2)) + \sqrt{D_3} \cot(\lambda(\theta_4 - \theta_2 + \kappa_3 + \kappa_4)) = 0 \quad (3.6)$$

in the case of Dirichlet boundary conditions.

*Proof.* Due to Theorem 2.19 all singular values  $\lambda$  have to satisfy (2.19) or (2.20), in the case of Neumann or Dirichlet boundary conditions, respectively. Since  $D_3 = D_4$  one has  $G_N(\lambda) = G_D(\lambda) = e^{i\lambda(\theta_4 - \theta_2 + \kappa_3 + \kappa_4)}$ . Thus, (2.19) simplifies to

$$\begin{aligned} 2i\sqrt{D_3}(F_N(\lambda) + F_N(-\lambda)) \sin(\lambda(\theta_4 - \theta_2 + \kappa_3 + \kappa_4)) \\ + 2\sqrt{D_2}(F_N(\lambda) - F_N(-\lambda)) \cos(\lambda(\theta_4 - \theta_2 + \kappa_3 + \kappa_4)) = 0. \end{aligned} \quad (3.7)$$

A singular value  $\lambda$  satisfies  $\sin(\lambda(\theta_4 - \theta_2 + \kappa_3 + \kappa_4)) = 0$ , iff the condition (3.1) is fulfilled: Indeed, by Definition 2.5 a singular value is nonzero and its real part belongs to the interval  $[0, 1[$ , while on the other hand one has  $0 < \theta_4 - \theta_2 + \kappa_3 + \kappa_4 < 3\pi$ , due to (2.16) and (2.18), since the opening angles  $\theta_4 - \theta_3$  and  $\theta_3 - \theta_2$  cannot both be greater or equal than  $\pi$ . Thus, unless (3.1) is fulfilled, (3.7) may be divided by  $\sin(\lambda(\theta_4 - \theta_2 + \kappa_3 + \kappa_4))$ , and one ends up with (3.2). The case of Dirichlet boundary conditions can be treated similarly.

The supposition  $D_1 = D_2$  implies  $F_N(\lambda) = F_D(\lambda) = e^{i\lambda(\theta_2 - \theta_0 + \kappa_1 + \kappa_2)}$ . Then (3.2) becomes

$$\begin{aligned} 2i\sqrt{D_3} \cos(\lambda(\theta_2 - \theta_0 + \kappa_1 + \kappa_2)) \\ + 2i\sqrt{D_2} \sin(\lambda(\theta_2 - \theta_0 + \kappa_1 + \kappa_2)) \cot(\lambda(\theta_4 - \theta_2 + \kappa_3 + \kappa_4)) = 0. \end{aligned} \quad (3.8)$$

If a singular value  $\lambda$  does not fulfil (3.4), then we can divide (3.8) by  $\sin(\lambda(\theta_2 - \theta_0 + \kappa_1 + \kappa_2))$  and end up with (3.5). In case of Dirichlet boundary conditions the proof is analogous.  $\square$

**Corollary 3.2.** *Suppose  $D_1 = D_2$  and  $D_3 = D_4$ . Then for Neumann and for Dirichlet boundary conditions all singular values are real, and there is an interval  $]0, \frac{1}{6} + \epsilon[$ ,  $\epsilon > 0$ , which does not contain singular values. If additionally none of the opening angles  $\theta_j - \theta_{j-1}$  exceeds  $\pi$ , then there is an interval  $]0, \frac{1}{4} + \epsilon[$ ,  $\epsilon > 0$ , which does not contain singular values.*

*Proof.* We explicitly conduct the proof only for Neumann boundary conditions. In case of Dirichlet boundary conditions one can proceed analogously. Let us assume that there are non-real singular values. A singular value  $\lambda$  with non-vanishing imaginary part satisfies (3.5). On the other hand the imaginary part of (3.5) cannot vanish, if  $\Im\lambda \neq 0$ . Indeed, the formula

$$\cot(\xi + i\eta) = \frac{\sin 2\xi - i \sinh \eta}{2 \sinh^2 \eta + 2 \sin^2 \xi}$$

shows that both cotangent terms in (3.5) have a non-vanishing imaginary part with equal sign, since, due to (2.16) and (2.18),  $\theta_2 - \theta_0 + \kappa_1 + \kappa_2$  and  $\theta_4 - \theta_2 + \kappa_3 + \kappa_4$  are positive. Hence, there are only real singular values.

Due to (2.16) and (2.18),  $\theta_2 - \theta_0 + \kappa_1 + \kappa_2$  and  $\theta_4 - \theta_2 + \kappa_3 + \kappa_4$  are smaller than  $3\pi$ , and even smaller than  $2\pi$ , if all the opening angles are smaller than  $\pi$ . Consequently, the arguments of the cotangent in (3.5) are in  $]0, \pi/2[$  for the asserted values of  $\lambda$  so that the left hand side of (3.5) is strictly positive. Thus, these values of  $\lambda$  cannot be singular. Furthermore, the exceptional cases (3.1) and (3.4) cannot occur for these values of  $\lambda$ .  $\square$

### 3.2 Three materials

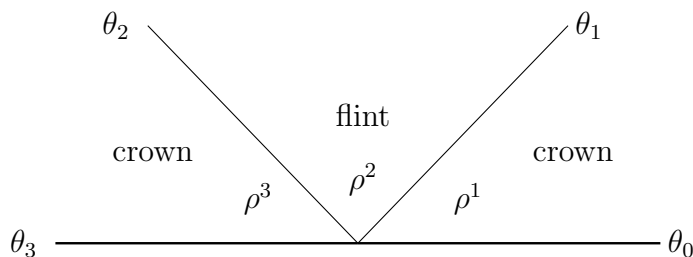
In this section we consider an edge where three materials meet. The direct vision prism, see Figure 1, exemplifies this constellation. The two-dimensional configuration of Definition 2.1 corresponding to the direct vision prism in Figure 1 by way of Definition 2.6 is depicted in Figure 5.

Here we regard the three-material edge as the special case of the four-material configuration from Section 2.4 with equal coefficient matrices  $\rho^3$  and  $\rho^4$ . First we calculate how the angle of anisotropy, see Definition 2.14, for the mono-material sector  $K_{\theta_2}^{\theta_4}$  is related to the angles of anisotropy  $\kappa_3$  and  $\kappa_4$  of the sectors  $K_{\theta_2}^{\theta_3}$  and  $K_{\theta_3}^{\theta_4}$ , respectively.

**Lemma 3.3.** *In the constellation of Definition 2.1 with  $n = 4$  for the quantities (2.8) and (2.9) holds true: If  $\varsigma_4 = \varsigma_3$ , then*

$$\kappa_3 + \kappa_4 = \kappa \stackrel{\text{def}}{=} \arg \frac{\bar{\varsigma}_3 e^{-2i\theta_4} + 1}{\bar{\varsigma}_3 e^{-2i\theta_2} + 1}. \quad (3.9)$$





**Figure 5:** Edge pencil of the three-material edge in the direct vision prism of Figure 1 composed of optical crown, flint, and crown again. For this constellation the angles are approximately  $\theta_0 = 0$ ,  $\theta_1 = 0.8$ ,  $\theta_2 = 2.3$ ,  $\theta_3 = \pi$ . Thus, the opening angles of all sectors are smaller than  $\pi/2$ .

That means  $\kappa$  is the angle of anisotropy (see Definition 2.14) for the mono-material sector  $K_{\theta_2}^{\theta_4}$ . Moreover,

$$\begin{aligned} \theta_4 - \theta_2 \in ]0, \pi[ , & \quad \text{iff} \quad \theta_4 - \theta_2 + \kappa \in ]0, \pi[ , \\ \theta_4 - \theta_2 = \pi, & \quad \text{iff} \quad \theta_4 - \theta_2 + \kappa = \pi, \\ \theta_4 - \theta_2 \in ]\pi, 2\pi[ , & \quad \text{iff} \quad \theta_4 - \theta_2 + \kappa \in ]\pi, 2\pi[ . \end{aligned} \quad (3.10)$$

*Proof.* By Definition 2.14 one has

$$\begin{aligned} e^{i(\kappa_3 + \kappa_4)} &= \frac{\bar{\zeta}_3 e^{-2i\theta_3} + 1}{\bar{\zeta}_3 e^{-2i\theta_2} + 1} \frac{|\bar{\zeta}_3 e^{-2i\theta_2} + 1|}{|\bar{\zeta}_3 e^{-2i\theta_3} + 1|} \frac{\bar{\zeta}_3 e^{-2i\theta_4} + 1}{\bar{\zeta}_3 e^{-2i\theta_3} + 1} \frac{|\bar{\zeta}_3 e^{-2i\theta_3} + 1|}{|\bar{\zeta}_3 e^{-2i\theta_4} + 1|} \\ &= \frac{\bar{\zeta}_3 e^{-2i\theta_4} + 1}{\bar{\zeta}_3 e^{-2i\theta_2} + 1} \frac{|\bar{\zeta}_3 e^{-2i\theta_2} + 1|}{|\bar{\zeta}_3 e^{-2i\theta_4} + 1|} = e^{i\kappa}. \end{aligned}$$

Thus,  $\theta_4 - \theta_2 + \kappa_3 + \kappa_4 = \theta_4 - \theta_2 + \kappa + 2k\pi$ , for some integer  $k$ . We show that  $k$  must be zero.

If both opening angles  $\theta_3 - \theta_2$  and  $\theta_4 - \theta_3$  are strictly smaller than  $\pi$ , then due to (2.16) we have  $0 < \theta_4 - \theta_2 + \kappa_3 + \kappa_4 < 2\pi$ . On the other hand Lemma 2.17 with  $\chi = \bar{\zeta}_3 e^{-2i\theta_2}$  and  $\zeta = \theta_4 - \theta_2$  provides  $0 < \theta_4 - \theta_2 + \kappa < 2\pi$ . Hence,  $k = 0$ .

If one of the opening angles  $\theta_3 - \theta_2$  or  $\theta_4 - \theta_3$  is not smaller than  $\pi$ , then according to (2.18) we have  $\pi < \theta_4 - \theta_2 + \kappa_3 + \kappa_4 < 3\pi$ , while Lemma 2.17 provides  $\pi < \theta_4 - \theta_2 + \kappa < 2\pi$ . Hence, again  $k = 0$ .

Now (3.10) immediately follows from Corollary 2.18 and the definition of  $\kappa$  in (3.9).  $\square$

By means of Lemma 3.3 one can now specialise Theorem 3.1.

**Theorem 3.4.** *Under the assumptions made in Theorem 3.1, and, additionally, assuming that the coefficient matrices  $\rho^3$  and  $\rho^4$  are equal, and that  $\kappa = \kappa_3 + \kappa_4$  is given by (3.9) the following holds true:*

1. *Every singular value  $\lambda \neq \pi/(\theta_4 - \theta_2 + \kappa)$  satisfies (3.2), if Neumann boundary conditions are imposed, and obeys (3.3), if Dirichlet boundary conditions are imposed.*

2. *Suppose additionally that the determinants  $D_1$  and  $D_2$  of the coefficient matrices  $\rho^1$  and  $\rho^2$ , respectively, are equal. Then all singular values are real and every singular value which is not equal to  $\pi/(\theta_2 - \theta_0 + \kappa_1 + \kappa_2)$  or  $2\pi/(\theta_2 - \theta_0 + \kappa_1 + \kappa_2)$  satisfies*

$$\sqrt{D_3} \cot(\lambda(\theta_2 - \theta_0 + \kappa_1 + \kappa_2)) + \sqrt{D_2} \cot(\lambda(\theta_4 - \theta_2 + \kappa)) = 0 \quad (3.11)$$

*in case of Neumann boundary conditions and*

$$\sqrt{D_2} \cot(\lambda(\theta_2 - \theta_0 + \kappa_1 + \kappa_2)) + \sqrt{D_3} \cot(\lambda(\theta_4 - \theta_2 + \kappa)) = 0 \quad (3.12)$$

*in case of Dirichlet boundary conditions.*

3. *If  $D_1 = D_2 = D_3$ , then (3.11) and (3.12) are equivalent to*

$$\sin(\lambda(\theta_4 - \theta_0 + \kappa_1 + \kappa_2 + \kappa)) = 0, \quad (3.13)$$

*provided that  $\lambda$  is none of the values  $k\pi/(\theta_2 - \theta_0 + \kappa_1 + \kappa_2)$ ,  $k = 1, 2$  and  $\pi/(\theta_4 - \theta_2 + \kappa)$ .*

*Proof.* The first assertion follows from the first part of Theorem 3.1 and Lemma 3.3. Note that the second value, excluded by (3.1), is here larger than 1, due to (3.10), hence, not a singular value by Definition 2.5.

As for the second assertion, from Corollary 3.2 immediately follows that the singular values are real. Furthermore, (3.11) and (3.12) result from the second part of Theorem 3.1 and Lemma 3.3.

Finally, to see that (3.13) is equivalent to (3.11) and (3.12), one uses the angle sum formula for the cotangent.  $\square$

Next, under the general assumptions  $\rho^3 = \rho^4$  and  $D_1 = D_2$ , we state lower bounds for the singular values, which are all real in this case, see Theorem 3.4.

**Theorem 3.5.** *Under the assumptions made in Theorem 3.1, and, additionally, assuming that the coefficient matrices  $\rho^3$  and  $\rho^4$  are equal, and that the determinants  $D_1$  and  $D_2$  are equal, there is an  $\epsilon > 0$ , such that the following holds true:*

1. *If the opening angles  $\theta_1 - \theta_0$  and  $\theta_2 - \theta_1$  of the first two material sectors do not exceed  $\pi$ , then all singular values are greater than  $1/4 + \epsilon$  both in the case of Neumann and of Dirichlet boundary conditions.*

2. If the opening angles  $\theta_1 - \theta_0$ ,  $\theta_2 - \theta_1$ , and  $\theta_4 - \theta_2$  of the three material sectors are not greater than  $\pi$ , and if at least one of the sectors  $K_{\theta_0}^{\theta_1}$ ,  $K_{\theta_1}^{\theta_2}$  has an opening angle not larger than  $\pi/2$ , and if the corresponding coefficient matrix is scalar, then all singular values are greater than  $1/3 + \epsilon$ .

3. If  $D_1 = D_2 = D_3$ , then the singular values are greater than  $1/4 + \epsilon$ . If, additionally, no opening angle exceeds  $\pi$ , then the singular values are even greater than  $1/3 + \epsilon$ .

*Proof.* To prove the first assertion we note that the values (3.4) are larger than  $1/3$ , since  $\theta_1 - \theta_0$  and  $\theta_2 - \theta_1$  do not both exceed  $\pi$ , see (2.18). Hence, it suffices to prove that (3.11), (3.12) cannot be fulfilled for a  $\lambda \in ]0, 1/4 + \epsilon]$ . (2.16) shows that  $0 < \theta_2 - \theta_0 + \kappa_1 + \kappa_2 \leq 2\pi$ , and  $0 < \theta_4 - \theta_2 + \kappa < 2\pi$ . Consequently, the left hand side of (3.11) and (3.12) cannot vanish for  $\lambda \in ]0, 1/4 + \epsilon]$  for some  $\epsilon > 0$ .

As for the second assertion it suffices to prove that (3.11) and (3.12) cannot be fulfilled for a  $\lambda \in ]0, 1/3 + \epsilon]$ . If  $\rho^1$  or  $\rho^2$  is a multiple of the identity matrix, then either  $\varsigma_1 = 0$  or  $\varsigma_2 = 0$ , see (2.8). Hence, either  $\kappa_1 = 0$  or  $\kappa_2 = 0$ , see (2.9). Thus, according to the supposition on the corresponding opening angle, by (2.15) we have  $0 < \theta_2 - \theta_0 + \kappa_1 + \kappa_2 \leq 3\pi/2$ . On the other hand,  $0 < \theta_4 - \theta_2 \leq \pi$ , consequently,  $0 < \theta_4 - \theta_2 + \kappa \leq \pi$  by (3.10). Hence, (3.11) and (3.12) cannot be zero as long as  $\lambda \in ]0, 1/3 + \epsilon]$  for some suitable  $\epsilon > 0$ .

Since at most one opening angle can be greater or equal  $\pi$ , the third assertion follows from the inequalities (2.15) and (3.10).  $\square$

**Remark 3.6.** In order to pass from four to three sectors, one naturally also can put  $\rho^1 = \rho^2$  (or  $\rho^2 = \rho^3$ ). Analogously to Lemma 3.3 one proves that the angle of anisotropy, see Definition 2.14, for the mono-material sector  $K_{\theta_0}^{\theta_2}$  (or  $K_{\theta_1}^{\theta_3}$ , respectively) is the sum of the angles of anisotropy of the two merged sectors. This allows to proceed again as in the preceding considerations.

Let us now summarise the results for the three-material constellation.

**Theorem 3.7.** *Let us regard the configuration of Definition 2.1 with  $n = 3$ . We assume  $D_1 = D_2$  and that no opening angle of a sector exceeds  $\pi$ . Additionally, one of the following conditions shall be satisfied:*

$$(1 + |\varsigma_1|^2) \cos(\theta_1 - \theta_0) + 2\Re\varsigma_1 \cos(\theta_0 + \theta_1) - 2\Im\varsigma_1 \sin(\theta_0 + \theta_1) > 0, \quad (3.14)$$

$$(1 + |\varsigma_2|^2) \cos(\theta_2 - \theta_1) + 2\Re\varsigma_2 \cos(\theta_1 + \theta_2) - 2\Im\varsigma_2 \sin(\theta_1 + \theta_2) > 0. \quad (3.15)$$

*Then all singular values, see Definition 2.5 are real and not smaller than  $1/3 + \epsilon$  for some  $\epsilon > 0$ . This holds for Neumann as well as for Dirichlet boundary conditions.*

*Proof.* It suffices to show that  $\theta_2 - \theta_0 + \kappa_1 + \kappa_2 < \frac{3\pi}{2}$ . Since, according to (2.15),  $0 < \theta_1 - \theta_0 + \kappa_1 \leq \pi$  and  $0 < \theta_2 - \theta_1 + \kappa_2 \leq \pi$  this is the case if  $\theta_1 - \theta_0 + \kappa_1 < \pi/2$  or  $\theta_2 - \theta_1 + \kappa_2 < \pi/2$ . Thus, it suffices to prove that  $\Re e^{i(\theta_1 - \theta_0 + \kappa_1)} > 0$  or  $\Re e^{i(\theta_2 - \theta_1 + \kappa_2)} > 0$ . Let us first assume that (3.14) is fulfilled. By means of (2.14) with  $\zeta = \theta_1 - \theta_0$  and  $\chi = \bar{\varsigma}_1 e^{-2i\theta_0}$  one obtains

$$\Re e^{i(\theta_1 - \theta_0 + \kappa_1)} = \frac{(1 + |\varsigma_1|^2) \cos(\theta_1 - \theta_0) + 2\Re \varsigma_1 \cos(\theta_0 + \theta_1) - 2\Im \varsigma_1 \sin(\theta_0 + \theta_1)}{|\varsigma_1 e^{-2i\theta_0} + 1| |\varsigma_1 e^{-2i\theta_1} + 1|} > 0.$$

In case of (3.15) one similarly gets  $\Re e^{i(\theta_2 - \theta_1 + \kappa_2)} > 0$ .  $\square$

**Remark 3.8.** The inequality (3.14) (or (3.15)) is satisfied under the following condition: The sector  $K_{\theta_0}^{\theta_1}$  (or  $K_{\theta_1}^{\theta_2}$ , respectively) does not intersect neither the  $x$ -axis nor the  $y$ -axis, and the coefficient matrix  $\rho^1$  (or  $\rho^2$ , respectively) is diagonal.

Indeed, if  $\rho^1$  is diagonal, then  $\varsigma_1$  is real (see (2.8)) and (3.14) is equivalent to the condition

$$\cos(\theta_1 - \theta_0) + \frac{2\varsigma_1}{1 + \varsigma_1^2} \cos(\theta_0 + \theta_1) \geq 0.$$

Thus, since  $2\varsigma_1/(1 + \varsigma_1^2) \leq 1$ , we conclude that  $\Re e^{i(\theta_1 - \theta_0 + \kappa_1)}$  is nonnegative if  $\cos(\theta_1 - \theta_0) \geq |\cos(\theta_0 + \theta_1)|$ . This can be readily verified since  $K_{\theta_0}^{\theta_1}$  does not intersect a coordinate axis. The case of the sector  $K_{\theta_1}^{\theta_2}$  and the matrix  $\rho^2$  is analogous.

## 4 Computation of singular values

The computation of the singular values for a constellation as in Definition 2.1 — here specialised to just four materials — is based upon Theorem 2.19. One has to find the zeros of the characteristic function

$$\begin{aligned} f_N(\lambda) \stackrel{\text{def}}{=} & \sqrt{D_3} (F_N(\lambda) + F_N(-\lambda)) (G_N(\lambda) - G_N(-\lambda)) \\ & + \sqrt{D_2} (F_N(\lambda) - F_N(-\lambda)) (G_N(\lambda) + G_N(-\lambda)), \quad \lambda \in \mathbb{C} \end{aligned} \quad (4.1)$$

in case of Neumann boundary conditions, and of

$$\begin{aligned} f_D(\lambda) \stackrel{\text{def}}{=} & \sqrt{D_3} (F_D(\lambda) - F_D(-\lambda)) (G_D(\lambda) + G_D(-\lambda)) \\ & + \sqrt{D_2} (G_D(\lambda) - G_D(-\lambda)) (F_D(\lambda) + F_D(-\lambda)), \quad \lambda \in \mathbb{C} \end{aligned} \quad (4.2)$$

in case of Dirichlet boundary conditions. We only sketch how to proceed to determine these zeros. For computing the zeros of analytic functions in

general we refer to the specialised literature, see e.g. [38] and references cited there. The handling of clusters of zeros, in particular, was treated in [22].

First we note that  $\lambda = 0$  is a zero of both  $f_N$  and  $f_D$ , but is by Definition 2.5 not a singular value. Indeed, in the case of Dirichlet boundary conditions  $\ker \mathcal{A}_0$  is trivial, and it contains only the constant functions in the case of Neumann boundary conditions. Thus,  $\lambda = 0$  does not correspond to singular solutions of the elliptic operators from Definition 2.1. Hence, we start our consideration by separating the case  $\lambda = 0$ .

**Lemma 4.1.** *The functions  $f_N$  and  $f_D$ , see (4.1) and (4.2), respectively, are entire and vanish at zero of order 1.*

*Proof.* We explicitly verify the assertion only for  $f_N$ , but, one can analogously do so for  $f_D$ . The first derivative of  $f_N$  in  $\lambda = 0$  is

$$\begin{aligned} f'_N(0) &= 4\sqrt{D_3}F_N(0)G'_N(0) + 4\sqrt{D_2}G_N(0)F'_N(0) \\ &= 4\sqrt{D_3}\frac{2\sqrt{D_2}}{\sqrt{D_1+\sqrt{D_2}}} \left( i(\theta_4 - \theta_2 + \kappa_3 + \kappa_4)\frac{2\sqrt{D_3}}{\sqrt{D_3+\sqrt{D_4}}} \right. \\ &\quad \left. - 2i(\theta_4 - \theta_3 + \kappa_4)\frac{\sqrt{D_3-\sqrt{D_4}}}{\sqrt{D_3+\sqrt{D_4}}} \right) \\ &\quad + 4\sqrt{D_2}\frac{2\sqrt{D_3}}{\sqrt{D_3+\sqrt{D_4}}} \left( i(\theta_2 - \theta_0 + \kappa_1 + \kappa_2)\frac{2\sqrt{D_2}}{\sqrt{D_1+\sqrt{D_2}}} \right. \\ &\quad \left. + 2i(\theta_1 - \theta_0 + \kappa_1)\frac{\sqrt{D_1-\sqrt{D_2}}}{\sqrt{D_1+\sqrt{D_2}}} \right) \\ &= \frac{16i\sqrt{D_2D_3}}{(\sqrt{D_1+\sqrt{D_2}})(\sqrt{D_3+\sqrt{D_4}})} \sum_{j=1}^4 (\theta_j - \theta_{j-1} + \kappa_j)\sqrt{D_j}. \end{aligned}$$

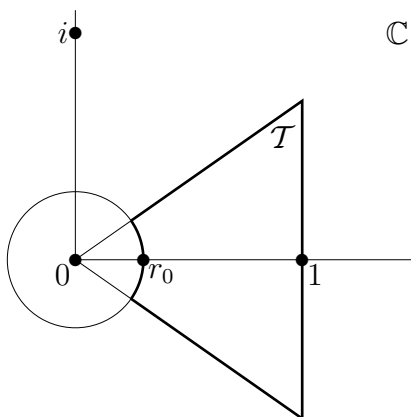
According to (2.15), this expression can never vanish.  $\square$

Based upon the bounds for the singularities one can determine the relevant zeros of the functions  $f_N$  and  $f_D$  by means of the following generalisation of Cauchy's argument principle, see e.g. [28, Ch. 1, §9].

**Proposition 4.2.** *Let  $\Upsilon \subset \mathbb{C}$  be a bounded domain whose boundary  $\partial\Upsilon$  is a closed, piecewise  $C^1$  curve. If  $f$  is an analytic function on  $\Upsilon$  which does never vanish on  $\partial\Upsilon$ , then*

$$\sum_{\ell} z_{\ell}^k = \frac{1}{2\pi i} \int_{\partial\Upsilon} z^k \frac{f'(z)}{f(z)} dz, \quad (4.3)$$

where  $k$  is a nonnegative integer, and the  $\{z_{\ell}\}$  are the roots of  $f$  within  $\Upsilon$  repeated according to multiplicity.



**Figure 6:** A triangle  $\mathcal{T}$ , see (4.4), encloses all singular values. More precisely, the thick line already does so, since the disc  $|\lambda| \leq r_0$  does not contain roots of the characteristic function apart of  $\lambda = 0$ .

Now we outline an algorithm to determine the zeros of the functions (4.1) and (4.2). In the following  $f$  is  $f_N$  or  $f_D$ , respectively.

1. By Definition 2.5 and according to Theorem 2.9 all singular values of the problem are in the interior of a triangle

$$\mathcal{T} \stackrel{\text{def}}{=} \left\{ \lambda_1 + i\lambda_2 : |\lambda_2| \leq \lambda_1 \left( \epsilon + \max_{1 \leq j \leq n} \frac{\text{tr } \rho^j}{2\sqrt{\det \rho^j}} \right), 0 < \lambda_1 < 1 \right\} \quad (4.4)$$

for any  $\epsilon > 0$ , see Figure 6. Please note that, due to Theorem 2.19, outside  $\mathcal{T}$  there are no zeros of  $f$  with real part in  $]0, 1[$ . Since  $f$  is entire, see Lemma 4.1, its roots have no finite limit point such that there is only a finite number of singular values.

2. According to Lemma 4.1 the zeros of  $f$  cannot accumulate at zero. Hence, there is a disc  $|\lambda| \leq r_0$  which does not contain zeros of  $f$  apart of  $\lambda = 0$ , see Figure 6. Using (4.3) with  $k = 0$  and  $\Upsilon$  given by discs with centre zero, one can compute  $r_0$  as the radius where (4.3) — regarded as a function of the disc radius — jumps between one (inside  $|\lambda| < r_0$ ) and an integer greater than one. Thus, by nesting intervals one easily gets an approximate of  $r_0$ .

3. The total number of singular values is given by (4.3) with  $k = 0$  and  $\Upsilon = \mathcal{T} \setminus \{|\lambda| \leq r_0\}$ . By nesting intervals one now can split up this domain  $\Upsilon$  into a finite number of sub-domains  $\Upsilon_\ell$  such that each sub-domain contains exactly one root of  $f$ . Moreover, the multiplicity of each root is finite. Please note that again (4.3) — regarded as a function of such sub-domains — is a step function, thus, well suited for an algorithm of nested intervals.

4. Finally, to compute the zeros of  $f$  themselves, one makes use of the finite partition  $\Upsilon = \text{int}(\cup_\ell \text{cl } \Upsilon_\ell)$  from the previous step, and applies (4.3) with  $k = 1$  and  $\Upsilon = \Upsilon_\ell$  to get the single zero  $\lambda_\ell$  of  $f$  inside  $\Upsilon_\ell$ .

A difficulty in the implementation of the procedure outlined above is to be struck by zeros of  $f$  on the boundary of prospective domains for the

application of Proposition 4.2. In particular zeros of  $f$  with real part 1 pose a problem. Since  $f$  is entire, see Lemma 4.1, there is only a finite number of roots on the boundary of (4.4). Thus, ultimately, one can split off all roots on the boundary of  $\mathcal{T}$  with real part 1 very much in the same way as we have split off the root  $\lambda = 0$ .

## 5 Application: L–shape of different materials

In this section we apply our results exemplarily to an elliptic div-grad operator  $-\nabla \cdot \mu \nabla$ , acting on a three dimensional polyhedral Lipschitz domain, and we assume that the coefficient function  $\mu$  is constant on sub-polyhedra, see Definition 2.6. There is a vast literature on such transmission problems, and in particular about the aspects of (almost) optimal regularity and anisotropy of the coefficient matrices  $\mu$ . We only just quote a few in lieu of many others.

The case of a layered structure was treated long ago in [10], but compare also [8], [43], and [53]. In [18] and [19] more general structures were regarded with Dirichlet boundary conditions, and the continuity of  $-\nabla \cdot \mu \nabla: W_0^{1,q} \rightarrow W^{-1,q}$  for some  $q > 3$  was obtained. In the spatially three-dimensional case, the spaces  $W^{-1,q}(\Omega)$  with  $q > 3$  are adequate for elliptic equations with right hand sides which include for instance measures concentrated on a surface within the three-dimensional basic domain  $\Omega$ . Think of surface charges in electrostatics; they cause a jump of the conormal derivative of the electrostatic potential across the surface bearing the charge. This is not coincidental, but generally the *adaequatio* of the mathematical model and the underlying physics also shows up in the regularity of solutions and corresponding entities in nature.

The three-dimensional L–shape of two different materials, see Figure 7, which was regarded in [15, Fig. 2] and [50, Fig. 1] may be viewed as a local part of a polyhedral Lipschitz domain composed of sub-polyhedra of different homogeneous — but, possibly anisotropic — materials, see Definition 2.6. For an example of such a domain look at the ridge waveguide multiple quantum well laser of Figure 2. The crucial point is that the material interface can meet the boundary in a region where localisation intrinsically fails to provide a convex domain.

We regard elliptic div-grad operators  $-\nabla \cdot \mu \nabla$  with mixed boundary conditions on the L–shape domain. Since Dirichlet boundary conditions were treated in [18] we regard Neumann boundary conditions in the corner. However, Theorem 3.4 also allows to treat again the optimal regularity problem with Dirichlet boundary conditions in the corner.

Our result for the L–shape of different materials generalises that of [50] to

coefficient functions  $\mu$  which are anisotropic material tensors. Moreover, we get an optimal regularity result within the scale of  $W^{1,q}$  spaces. On this scale — in contrast to the scale of  $H^{s,2}$  spaces — the space of optimal regularity embeds into a Hölder space. Thus, our optimal regularity result fits into a unified treatment of quasi-linear parabolic equations, see [48] or [27].

First we define the relevant function spaces and elliptic div-grad operators. We regard the constellation of Definition 2.6.

**Definition 5.1.** If  $\Omega \subset \mathbb{R}^3$  is a bounded Lipschitz domain and  $\Gamma \subset \partial\Omega$  is an open part of its boundary, then we denote by  $W_\Gamma^{1,p}(\Omega)$  the closure of

$$\{v|_\Omega : v \in C^\infty(\mathbb{R}^3), \text{supp } v \cap (\partial\Omega \setminus \Gamma) = \emptyset\}$$

in the Sobolev space  $W^{1,p}(\Omega)$ .  $W_\Gamma^{-1,p'}(\Omega)$  with  $p' = p/(p-1)$  denotes the dual to  $W_\Gamma^{1,p}(\Omega)$ .

We now define an elliptic div-grad operator on  $\Omega$  with Neumann boundary conditions on  $\Gamma$  and Dirichlet boundary conditions on  $\partial\Omega \setminus \Gamma$ . According to Definition 2.6  $\Gamma$  is the interior of the closure of a finite union of faces of sub-polyhedra  $\Omega_k$ .

**Definition 5.2.** If  $\Omega \subset \mathbb{R}^3$  and  $\mu$  are as in Definition 2.6, and  $\Gamma$  is accordingly, then we define  $-\nabla \cdot \mu \nabla : W_\Gamma^{1,2}(\Omega) \rightarrow W_\Gamma^{-1,2}(\Omega)$  by

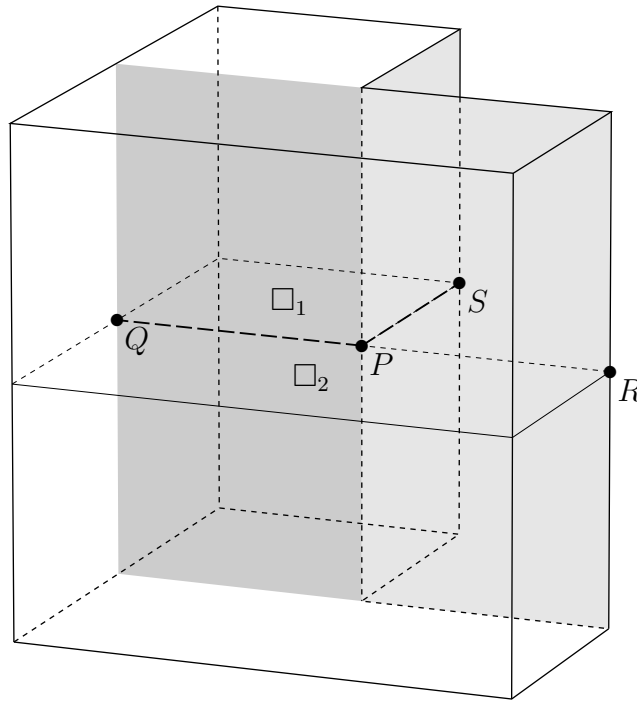
$$\langle -\nabla \cdot \mu \nabla v, w \rangle \stackrel{\text{def}}{=} \int_\Omega \mu \nabla v \cdot \nabla \bar{w} \, dx, \quad v, w \in W_\Gamma^{1,2}(\Omega),$$

where  $\langle u, w \rangle$  indicates the dual pairing of a function  $w \in W_\Gamma^{1,2}(\Omega)$  with a functional  $u \in W_\Gamma^{-1,2}(\Omega)$ . We denote the maximal restriction of  $-\nabla \cdot \mu \nabla$  to any of the spaces  $W_\Gamma^{-1,p}(\Omega)$ ,  $p > 2$ , by the same symbol.

**Definition 5.3.** Referring again to the constellation of Definition 2.6, we call  $E$  a *mono-material edge* of  $\Omega$ , if  $E \subset \partial\Omega$  and  $E$  belongs to the closure of exactly one sub-polyhedron  $\Omega_k$ . Analogously, we call  $E$  a *bi-material edge* of  $\Omega$ , if  $E \subset \partial\Omega$  and  $E$  belongs to the closure of exactly two sub-polyhedra. Hence,  $n$  in Remark 2.7 specialises to one or two, respectively. That means for every bi-material edge there exist uniquely determined angles  $\theta_0 < \theta_1 < \theta_2 < \theta_0 + 2\pi$  such that  $\mu_E$  corresponding to  $\mu$  by Definition 2.6 is constant on each of the sectors  $K_{\theta_0}^{\theta_1}$  and  $K_{\theta_1}^{\theta_2}$ , and takes there real, symmetric, positive definite  $2 \times 2$  matrices as values. Mutatis mutandis we speak of *three-material edge* and a *multi-material edge*.

Next we precisely define the three-dimensional L-shape of two different materials.

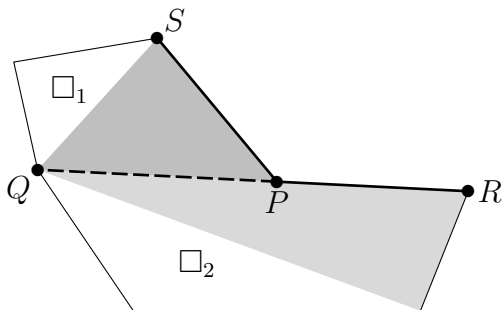




**Figure 7:** Three-dimensional L-shape  $\Pi$  of two different materials. The material interface is darkly shaded, and the boundary part  $\Gamma$  carrying Neumann boundary conditions is lightly shaded.  $\Pi$  is the Cartesian product of  $] -1, 1[$  with the quadrangles  $\square_1$  and  $\square_2$  in  $\mathbb{R}^2$ .

**Definition 5.4.** Let  $\square_1$  and  $\square_2$  in  $\mathbb{R}^2$  be two open, disjoint, convex quadrangles with one common vertex  $Q$ . Assume that one side of  $\square_1$  with endpoints  $Q$  and  $P$  is a proper part of a side  $\overline{QR}$  of  $\square_2$ . We denote the interior of the closure of  $\square_1 \cup \square_2$  by  $\Xi$  and define the prism  $\Pi \stackrel{\text{def}}{=} \Xi \times ] -1, 1[$ . If  $\overline{PS}$  is the second side of  $\square_1$ , ending in  $P$ , we define  $\Gamma \subset \partial\Pi$  by the Cartesian product of  $] -1, 1[$  with the interior of the piecewise linear curve  $\overline{SPR}$ . As in Definition 5.1  $\Gamma$  is the (open) part of  $\partial\Pi$  where Neumann boundary conditions are imposed. Furthermore,  $\mu$  is a coefficient function on  $\Pi$  with the values  $\mu_1$  and  $\mu_2$  on  $\square_1 \times ] -1, 1[$  and  $\square_2 \times ] -1, 1[$ , respectively, and  $\mu_1$  and  $\mu_2$  are real, symmetric, positive definite  $3 \times 3$  matrices. We name  $\Pi$  with this material-geometric constellation *three dimensional L-shape of two materials with mixed boundary conditions* or simply L-shape.

**Remark 5.5.** For the sake of the name we have build up the L-shape in Definition 5.4 from two disjoint, convex quadrangles  $\square_1$  and  $\square_2$  in  $\mathbb{R}^2$ . In particular, one or both of these quadrangles  $\square_1$  and  $\square_2$  may degenerate to a triangle  $\triangle_1$  and  $\triangle_2$ , respectively, see also Figure 8.



**Figure 8:** Cut through an L-shape by the  $x$ - $y$ -plane, see Definition 5.4. The dashed line  $\overline{QP}$  is the trace of the material interface, and the bold, piecewise linear curve  $\overline{SPR}$  is the trace of the surface area  $\Gamma$  where a Neumann boundary condition is imposed. The dark and fair shaded areas are triangles  $\Delta_1$  and  $\Delta_2$  for an alternative build-up of an L-shape, see Remark 5.5.

Finally, we state our result about the three-dimensional L-shape of two different materials and mixed boundary conditions. The proof of our theorem rests upon Theorem 3.5, and additionally requires nontrivial results from [48], see also [18] and [24].

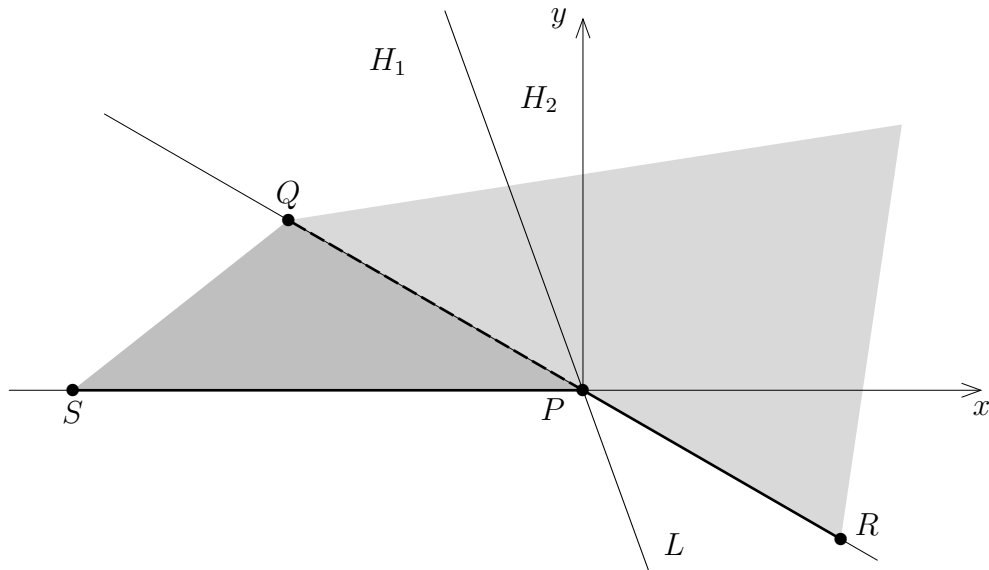
**Theorem 5.6.** *If  $\Pi$  is an L-shape in the sense of Definition 5.4, then there is a  $p > 3$  such that*

$$-\nabla \cdot \mu \nabla : W_{\Gamma}^{1,p}(\Pi) \rightarrow W_{\Gamma}^{-1,p}(\Pi)$$

*is a topological isomorphism.*

*Proof.* The optimal regularity statement of Theorem 5.6 is invariant under bi-Lipschitz mappings, see [24, Prop. 16]. Hence, in a first step of the proof we can transform the L-shape accordingly. We begin with a constellation as in Definition 5.4, see also Figure 8.

*Transformation 1:* Without loss of generality we may suppose that the point  $P$  is the origin of the coordinate system. We perform a rotation in the  $x$ - $y$ -plane such that the upper left  $2 \times 2$  block of the matrix  $\mu_2$ , associated to  $\square_2 \times ]-1, 1[$ , diagonalises. Then we dilate the  $x$ -axis (or the  $y$ -axis) such that the resulting upper left  $2 \times 2$  block becomes a multiple of the identity on  $\mathbb{R}^2$ . Next we again rotate in the  $x$ - $y$ -plane such that the transformed line  $\overline{PS}$  becomes a part of the negative  $x$ -axis. If the quadrangle  $\square_1$  is situated in the lower half of the  $x$ - $y$ -plane, we additionally reflect at the  $x$ -axis in the  $x$ - $y$ -plane. Thus, we end up with a transformed constellation, see Figure 9, where the image of the line  $\overline{PS}$  is part of the negative  $x$ -axis, the image of  $\square_1$  lies in the upper half of the  $x$ - $y$ -plane, and the left upper block of the transformed matrix  $\mu_2$  is a multiple of the identity on  $\mathbb{R}^2$ . We denote this transformation by  $\Theta_1$  and the image and the pre-image of  $\Theta_1$  by the same symbol.



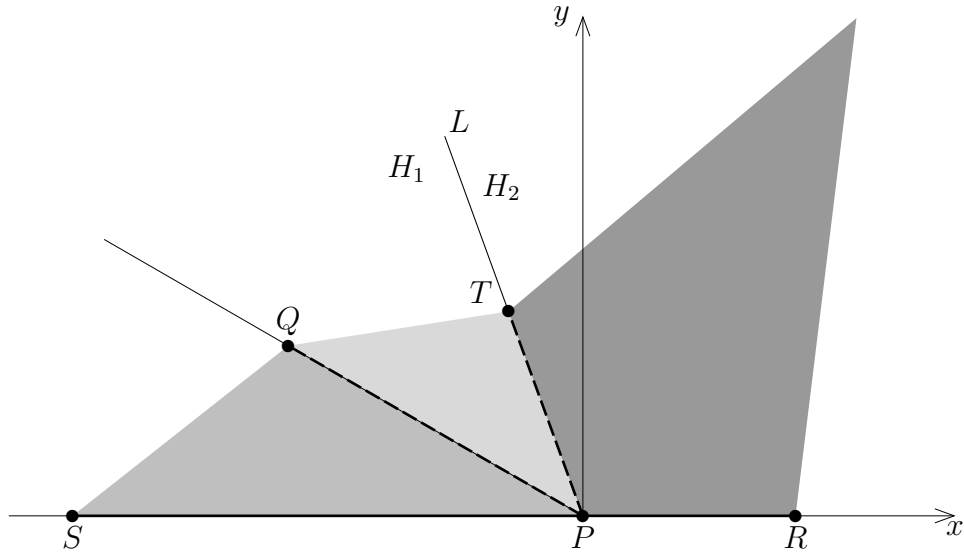
**Figure 9:** Cut through an L-shape by the  $x$ - $y$ -plane after Transformation 1, see the proof of Theorem 5.6. The dark and fair shaded area are the image of the correspondingly shaded parts of  $\square_1$  and  $\square_2$  in Figure 8. The dashed line  $\overline{PQ}$  is the trace of the material interface. The line  $L$  in  $\mathbb{R}^2$  through the origin  $P$  splits  $\mathbb{R}^2$  into half spaces  $H_1$  and  $H_2$  in such a way that the (transformed) quadrangle  $\square_1$  is fully in  $H_1$  and that moreover,  $L$  has an angle strictly between 0 and  $\pi/2$  with  $\overline{PQ}$ . The bold, piecewise linear curve  $\overline{SPR}$  is the trace of the surface area  $\Gamma$  where a Neumann boundary condition is imposed.

Let  $L$  be a line in  $\mathbb{R}^2$  through the origin  $P$ , which does not intersect  $\square_1$  and cuts through  $\square_2$  in such a way that the angle in  $\square_2$  between  $L$  and  $\overline{PQ}$  is strictly between 0 and  $\pi/2$ . We denote the component of  $\mathbb{R}^2 \setminus L$  which contains  $\square_1$  by  $H_1$ , the other by  $H_2$ .

*Transformation 2:* Now we define a linear mapping  $\Theta: \mathbb{R}^2 \rightarrow \mathbb{R}^2$  which is the identity on  $L$  and maps the point  $R$  onto a point of the positive  $x$ -axis in such a way that the determinant of  $\Theta$  has the absolute value 1. Figure 10 shows the constellation of Figure 9 after transformation by  $\Theta$ . Then

$$\Theta_2(x, y, z) \stackrel{\text{def}}{=} \begin{cases} (x, y, z) & \text{if } (x, y) \in H_1 \cup L, \\ (\Theta(x, y), z) & \text{if } (x, y) \in H_2 \end{cases} \quad (5.1)$$

provides a bi-Lipschitzian mapping of  $\mathbb{R}^3$  onto itself. The resulting object after applying  $\Theta_1$  and  $\Theta_2$  to the L-shape is the Cartesian product of the interval  $] -1, 1[$  of the  $z$ -axis with the image of  $\square$ , see Definition 5.4. On the interior of the side  $\overline{SR} \times ] -1, 1[$  — a rectangle in the  $x$ - $z$ -plane — Neumann



**Figure 10:** Cut through an L-shape by the  $x$ - $y$ -plane after the Transformations 1 and 2, see the proof of Theorem 5.6. The dashed line  $\overline{PQ}$  is the trace of the original material interface. After Transformation 2 there is a new material interface  $\overline{PT}$  on the line  $L$  separating the half-planes  $H_1$  and  $H_2$ . The transformation  $\Theta$ , see (5.1), is the identity on  $H_1 \cup L$ . The  $\Theta$ -image of the fair shaded area in Figure 9 is not a triangle anymore. On each of the differently shaded areas the coefficient matrix is constant. The union of all shaded areas is the image of all shaded areas in Figure 9. In particular, the fair and medium shaded areas have the same coefficients as the corresponding shades indicate in Figure 9. The bold segment  $\overline{SR}$  is the trace of the surface area  $\Gamma$  where a Neumann boundary condition is imposed.

boundary conditions are imposed. The edge  $E = P \times ]-1, 1[$  is a three-material edge, and its edge pencil, see Definition 2.6 and Definition 2.1 has the following properties: The opening angle  $\theta_2 - \theta_1$  of the middle sector is smaller than  $\pi/2$  and the corresponding matrix  $\rho_2$  is a positive multiple of the identity matrix. Moreover,  $\det \rho_2 = \det \rho_1$  since  $|\det \Theta| = 1$ ; nota bene the transformation rule for coefficient matrices of div-grad operators under bi-Lipschitz transforms, see [24, Prop. 16]. Hence, by the second statement of Theorem 3.5 all singular values of the edge pencil  $E$  are real and greater than  $1/3 + \epsilon$  for some  $\epsilon > 0$ .

*Transformation 3:* We now treat the L-shape  $\Pi$ , already transformed by  $\Theta_1$  and  $\Theta_2$ , by reflection at the  $x$ - $z$ -plane, see [24, Prop. 17]. Please note in

particular the rule [24, Eq. 22] of material reflection:

$$\rho(x, y) \stackrel{\text{def}}{=} \begin{cases} \begin{pmatrix} \rho_{11}^j & \rho_{12}^j \\ \rho_{12}^j & \rho_{22}^j \end{pmatrix} & \text{if } (x, y) \in K_{\theta_{j-1}}^{\theta_j}, \\ \begin{pmatrix} \rho_{11}^j & -\rho_{12}^j \\ -\rho_{12}^j & \rho_{22}^j \end{pmatrix} & \text{if } (x, -y) \in K_{\theta_{j-1}}^{\theta_j}. \end{cases}$$

Thus, we end up with an elliptic problem on a polyhedral domain with Dirichlet boundary conditions and constant coefficient matrices on polyhedral subdomains, more precisely we are in the constellation which was regarded in [18, §2.2]. Here the edges of this constellation are the interior edge  $E$  and mono- and bi-material edges on the boundary.

*Conclusion:* We now show that for all edges the real part of any singularity, see Definition 2.5, is greater than  $1/3 + \epsilon$  for some  $\epsilon > 0$ . Then the assertion of Theorem 5.6 follows by means of [18, Thm. 2.2].

The mono-material edges of our transformed problem do not have edge singularities with real part smaller or equal than  $1/2$ , see [24, Thm. 24]. The edge pencils at bi-material edges intersecting  $L$  only have opening angles not greater than  $\pi$  by construction. Hence, [24, Thm. 25] implies that the real part of these edge singularities is greater than  $1/2$ . The bi-material edge through the point  $Q$  is the result of Transformation 1. Since the pre-images  $\square_1$  and  $\square_2$  are convex, see Definition 5.4, the edge pencil at  $Q$  has opening angles smaller than  $\pi$ . Thus, again [24, Thm. 25] applies and the real part of these edge singularities too is greater than  $1/2$ . The same holds true for the reflected edge. As for the interior edge  $E$  the assertion follows from Theorem 3.5 and the following Proposition 5.7.  $\square$

**Proposition 5.7.** *Let us assume the constellation of Definition 2.1 and in particular  $\theta_0 = 0$  and  $\theta_n = \pi$ . Moreover, we define functions  $b_0$ ,  $b_1$ , and  $b_2$  almost everywhere on  $]-\pi, \pi]$  by*

$$\begin{aligned} b_0(-\theta) &\stackrel{\text{def}}{=} b_0(\theta) \stackrel{\text{def}}{=} \rho_{11}^j \cos^2 \theta + 2\rho_{12}^j \sin \theta \cos \theta + \rho_{22}^j \sin^2 \theta, \\ -b_1(-\theta) &\stackrel{\text{def}}{=} b_1(\theta) \stackrel{\text{def}}{=} (\rho_{22}^j - \rho_{11}^j) \sin \theta \cos \theta + \rho_{12}^j (\cos^2 \theta - \sin^2 \theta), \\ b_2(-\theta) &\stackrel{\text{def}}{=} b_2(\theta) \stackrel{\text{def}}{=} \rho_{11}^j \sin^2 \theta - 2\rho_{12}^j \sin \theta \cos \theta + \rho_{22}^j \cos^2 \theta \end{aligned}$$

for  $\theta_{j-1} < \theta < \theta_j$ ,  $j = 1, \dots, n$ . Further, we define for every  $\lambda \in \mathbb{C}$  the quadratic form

$$\int_{-\pi}^{\pi} b_2 \psi' \overline{\psi'} + \lambda b_1 \psi \overline{\psi'} - \lambda b_1 \psi' \overline{\psi} - \lambda^2 b_0 \psi \overline{\psi} d\theta,$$

$$\psi \in W^{1,2}(-\pi, \pi) \cap \{\psi : \psi(-\pi) = \psi(\pi)\}.$$

*Then for every  $\lambda \in \mathbb{C}$  with  $\Re\lambda > 0$  the operator induced by this quadratic form on  $L^2(-\pi, \pi)$  has a nontrivial kernel iff  $A_\lambda$  with Dirichlet boundary conditions has a nontrivial kernel and  $A_\lambda$  with Neumann boundary conditions has a nontrivial kernel, see Definition 2.3.*

Proposition 5.7 was proved in [24, Lemma 22] for the case  $0 = \theta_0 < \theta_1 < \theta_2 = \pi$ , that means for two sectors in the half plane  $y > 0$ . This proof mutatis mutandis carries over to the case of multiple sectors.

## 6 Concluding remarks

In this paper we have investigated the singularities of div-grad operators at a multi-material edge on a Dirichlet or a Neumann boundary part of the domain, see Definition 2.1. Analogously, it is possible to deal with the case of mixed boundary conditions which change from Dirichlet to Neumann at the edge. This can be done by specifying the space  $\mathcal{H}$  in Definition 2.3 appropriately between  $W_0^{1,2}(\theta_0, \theta_n)$  and  $W^{1,2}(\theta_0, \theta_n)$ . We have omitted to treat this case here explicitly, because it is well known that for this constellation even for bi-material edge examples there are arbitrarily small singular values, see [49] and [24, Rem. 28]. Nota bene, however, the model problems in [24] including mixed boundary conditions and material heterogeneities meeting at a point on the surface. On the other hand the analogon of Theorem 2.19 for a multi-material edge with mixed boundary conditions would allow to calculate the roots of the characteristic equation for every specific constellation. But then one already has the well established procedure from [13].

We have restricted our considerations here to the case of up to four materials meeting at an edge. Based upon the characterisation of singularities in Section 2.3 it is possible to derive transcendental equations for the singular values analogously to Section 2.4 also for other multi-material edges. However, this is cumbersome and one might be better off with using techniques from [13] right from the beginning then. Moreover, for more than four materials one cannot obviously delimitate constellations which allow uniform estimates of the real part of singularities from below.

In Section 3 we have characterised classes of multi-material problems with uniformly bounded singularities. The equivalence relation for classification is the equality of the determinant of the coefficient matrix for two or more materials at a multi-material edge. Thus, if there is no anisotropy, the multi-material edges under consideration in a specific class, actually, are edges with less materials around. In this sense we here have dealt with the generically anisotropic case.

## References

- [1] Loyce Adams and Zhilin Li, *The immersed interface/multigrid methods for interface problems*, SIAM J. Sci. Comput. **24** (2002), 463–479 (electronic).
- [2] R. E. Alcouffe, Achi Brandt, J. E. Dendy, Jr., and J. W. Painter, *The multigrid method for the diffusion equation with strongly discontinuous coefficients*, SIAM J. Sci. Statist. Comput. **2** (1981), 430–454.
- [3] U. Bandelow, R. Hünlich, and T. Koprucki, *Simulation of Static and Dynamic Properties of Edge-Emitting Multiple-Quantum-Well-Lasers*, IEEE Journal of Selected Topics in Quantum Electronics **9** (2003), 798–806.
- [4] D. J. BenDaniel and C. B. Duke, *Space-charge effects on electron tunneling*, Physical Review **152** (1966), 683–692.
- [5] Henri Berestycki, François Hamel, and Lionel Roques, *Analysis of the periodically fragmented environment model. I. Species persistence*, J. Math. Biol. **51** (2005), 75–113.
- [6] Ludwig Bergmann and Clemens Schaefer, *Optics of waves and particles*, Walter de Gruyter, Berlin, New York, 1999.
- [7] D. Bimberg, M. Grundmann, F. Heinrichsdorf, N.N. Ledentsov, Ch. Ribbat, Zh.I. Alferov, P.S.Kop’ev, M.V. Maximov, V.M. Ustinov, A.E. Zhudkov, and J.A. Lott, *Quantum dot lasers: Theory and experiment*, Nanoscale linear and nonlinear optics (Erice, Sicily) (M. Bertolotti, ed.), International School of Quantum Electronics, 2-14 July 2000, pp. 178–197.
- [8] L. A. Caffarelli and I. Peral, *On  $W^{1,p}$  estimates for elliptic equations in divergence form*, Comm. Pure Appl. Math. **51** (1998), 1–21.
- [9] Zhiming Chen and Jun Zou, *Finite element methods and their convergence for elliptic and parabolic interface problems*, Numer. Math. **79** (1998), 175–202.
- [10] Michel Chipot, David Kinderlehrer, and Giorgio Vergara-Caffarelli, *Smoothness of linear laminates*, Arch. Rational Mech. Anal. **96** (1986), 81–96.

- 
- [11] P. Colli Franzone, L. Guerri, and S. Rovida, *Wavefront propagation in an activation model of the anisotropic cardiac tissue: asymptotic analysis and numerical simulations*, *J. Math. Biol.* **28** (1990), 121–176.
- [12] Martin Costabel and Monique Dauge, *Computation of corner singularities in linear elasticity*, *Boundary value problems and integral equations in nonsmooth domains* (New York) (Martin Costabel et al., eds.), *Lect. Notes Pure Appl. Math.*, vol. 167, Marcel Dekker, 1995, Proceedings of the conference held at the CIRM, Luminy, France, May 3-7, 1993, pp. 59–68.
- [13] Martin Costabel, Monique Dauge, and Yvon Lafranche, *Fast semi-analytic computation of elastic edge singularities*, *Comput. Methods Appl. Mech. Eng.* **190** (2001), 2111–2134.
- [14] Monique Dauge, *Elliptic boundary value problems on corner domains. Smoothness and asymptotics of solutions*, *Lecture Notes in Mathematics*, 1341. Berlin etc.: Springer-Verlag, 1988.
- [15] ———, *Singularities of corner problems and problems of corner singularities*, *Actes du 30ème Congrès d’Analyse Numérique: CANum ’98* (Arles, 1998), *ESAIM Proc.*, vol. 6, Soc. Math. Appl. Indust., Paris, 1999, pp. 19–40 (electronic).
- [16] Yuri V. Egorov and Bert-Wolfgang Schulze, *Pseudo-differential operators, singularities, applications*, *Operator Theory: Advances and Applications*, vol. 93, Birkhäuser Verlag, Basel, 1997.
- [17] N. G. Einspruch and W. R. Frensley (eds.), *Heterostructures and quantum devices*, *VLSI Electronics: Microstructure Science*, vol. 24, Academic Press, San Diego, 1994.
- [18] Johannes Elschner, Hans-Christoph Kaiser, Joachim Rehberg, and Gunther Schmidt,  *$W^{1,q}$  regularity results for elliptic transmission problems on heterogeneous polyhedra*, *Mathematical Models & Methods in Applied Sciences* **17** (2007), 593–615.
- [19] Johannes Elschner, Joachim Rehberg, and Gunther Schmidt, *Optimal regularity for elliptic transmission problems including  $C^1$  interfaces*, *Interfaces Free Bound.* **9** (2007), 233–252.
- [20] H. Gajewski and K. Gröger, *Semiconductor equations for variable mobilities based on Boltzmann statistics or Fermi–Dirac statistics*, *Math. Nachr.* **140** (1989), 7–36.



- 
- [21] H. Gajewski and K. Gröger, *Reaction-diffusion processes of electrically charged species*, Math. Nachr. **177** (1996), 109–130.
- [22] M. Giusti, G. Lecerf, B. Salvy, and J.-C. Yakoubsohn, *On location and approximation of clusters of zeros of analytic functions*, Found. Comput. Math. **5** (2005), 257–311.
- [23] P. Grisvard, *Elliptic Problems in Nonsmooth Domains*, Monographs and Studies in Mathematics, vol. 24, Pitman, London, 1985.
- [24] Robert Haller-Dintelmann, Hans-Christoph Kaiser, and Joachim Rehberg, *Elliptic model problems including mixed boundary conditions and material heterogeneities*, Journal de Mathématiques Pures et Appliquées **89** (2008), 25–48.
- [25] Robert Haller-Dintelmann and Joachim Rehberg, *Maximal parabolic regularity for divergence operators including mixed boundary conditions*, J. Differential Equations **247** (2009), 1354–1396.
- [26] M. Herzberger, *Optical prism*, Optics source book (Sybil P. Parker, ed.), McGraw Hill, New York, 1988.
- [27] Matthias Hieber and Joachim Rehberg, *Quasilinear parabolic systems with mixed boundary conditions on nonsmooth domains*, SIAM J. Math. Anal. **40** (2008), 292–305.
- [28] Adolf Hurwitz, *Vorlesungen über allgemeine Funktionentheorie und elliptische Funktionen*, Herausgegeben und ergänzt durch einen Abschnitt über geometrische Funktionentheorie von R. Courant. Mit einem Anhang von H. Röhl. Vierte vermehrte und verbesserte Auflage. Die Grundlehren der Mathematischen Wissenschaften, Band 3, Springer-Verlag, Berlin, 1964 (German).
- [29] Tsung-Min Hwang, Wen-Wei Lin, Jinn-Liang Liu, and Weichung Wang, *Jacobi-Davidson methods for cubic eigenvalue problems*, Numer. Linear Algebra Appl. **12** (2005), 605–624.
- [30] E. M. Il'in, *Singularities of the weak solutions of elliptic equations with discontinuous higher coefficients. II. Corner points of the lines of discontinuity*, Zap. Naučn. Sem. Leningrad. Otdel. Mat. Inst. Steklov. (LOMI) **47** (1974), 166–169, 189, 194, Investigations on linear operators and the theory of functions, V.

- 
- [31] E. Kapon, *Semiconductor lasers I: Fundamentals*, Optics and Photonics, Academic Press, 1999.
- [32] T. Kato, *Perturbation theory for linear operators*, Grundlehren der mathematischen Wissenschaften, vol. 132, Springer Verlag, Berlin, 1984.
- [33] Massoud Kaviany, *Principles of heat transfer*, Wiley-Interscience, New York, 2002.
- [34] V. A. Kondrat'ev, *Boundary value problems for elliptic equations in domains with conical or angular points*, Trudy Moskov. Mat. Obsč. **16** (1967), 209–292.
- [35] ———, *Singularities of the solution of the Dirichlet problem for a second order elliptic equation in the neighborhood of an edge*, Differencial'nye Uravnenija **13** (1977), 2026–2032, 2109.
- [36] Thomas Koprucki, Hans-Christoph Kaiser, and Jürgen Fuhrmann, *Electronic states in semiconductor nanostructures and upscaling to semiclassical models*, Analysis, Modeling and Simulation of Multiscale Problems (Alexander Mielke, ed.), Springer, Berlin Heidelberg New York, 2006, pp. 367–396.
- [37] V. A. Kozlov, V. G. Maz'ya, and J. Rossmann, *Elliptic boundary value problems in domains with point singularities*, Mathematical Surveys and Monographs, vol. 52, American Mathematical Society, Providence, RI, 1997.
- [38] Peter Kravanja and Marc Van Barel, *Computing the zeros of analytic functions*, Lecture Notes in Mathematics, vol. 1727, Springer-Verlag, Berlin, 2000.
- [39] L. D. Landau and E. M. Lifshitz, *Course of theoretical physics. Vol. 5: Statistical physics*, Translated from the Russian by J. B. Sykes and M. J. Kearsley. Second revised and enlarged edition, Pergamon Press, Oxford, 1968.
- [40] ———, *Course of theoretical physics. Vol. 8*, Pergamon International Library of Science, Technology, Engineering and Social Studies, Pergamon Press, Oxford, 1984, Electrodynamics of continuous media, Translated from the second Russian edition by J. B. Sykes, J. S. Bell and M. J. Kearsley, Second Russian edition revised by Lifshits and L. P. Pitaevskii.

- 
- [41] Elisabeth Larsson and Sverker Holmgren, *Parallel solution of the Helmholtz equation in a multilayer domain*, BIT **43** (2003), 387–411.
- [42] D. Leguillon and E. Sánchez-Palencia, *Computation of singular solutions in elliptic problems and elasticity*, John Wiley & Sons Ltd., Chichester, 1987.
- [43] Yan Yan Li and Michael Vogelius, *Gradient estimates for solutions to divergence form elliptic equations with discontinuous coefficients*, Arch. Ration. Mech. Anal. **153** (2000), 91–151.
- [44] Yiming Li, Jinn-Liang Liu, O. Voskoboynikov, C. P. Lee, and S. M. Sze, *Electron energy level calculations for cylindrical narrow gap semiconductor quantum dot*, Computer Physics Communications **140** (2001), 399–404.
- [45] V. G. Maz'ja and B. A. Plamenevskii,  *$L^p$  estimates of solutions of elliptic boundary value problems in a domain with edges*, Trans. Moscow Math. Soc. **1** (1980), 49–97.
- [46] ———, *On boundary value problems for a second order elliptic equation in a domain with edges*, Vestnik Leningrad Univ. Mathematics **8** (1980), 99–106.
- [47] Vladimir Gilelevič Maz'ja and Jürgen Rossmann, *Über die Asymptotik der Lösungen elliptischer Randwertaufgaben in der Umgebung von Kanten*, Math. Nachr. **138** (1988), 27–53.
- [48] V. Maz'ya, J. Elschner, J. Rehberg, and G. Schmidt, *Solutions for quasi-linear nonsmooth evolution systems in  $L^p$* , Arch. Ration. Mech. Anal. **171** (2004), 219–262.
- [49] D. Mercier, *Minimal regularity of the solutions of some transmission problems*, Math. Methods Appl. Sci. **26** (2003), 321–348.
- [50] Serge Nicaise and Anna-Margarete Sändig, *Transmission problems for the Laplace and elasticity operators: regularity and boundary integral formulation*, Math. Models Methods Appl. Sci. **9** (1999), 855–898.
- [51] Netta Omer and Zohar Yosibash, *Edge singularities in 3-D elastic anisotropic and multi-material domains*, Comput. Methods Appl. Mech. Engrg. **197** (2008), 959–978.
- [52] M. Petzoldt, *Regularity results for Laplace interface problems in two dimensions*, Z. Anal. Anwendungen **20** (2001), 431–455.

- [53] Giuseppe Savaré, *Regularity results for elliptic equations in Lipschitz domains*, J. Funct. Anal. **152** (1998), 176–201.
- [54] Clemens Schaefer and Max Päsler, *Einführung in die Theoretische Physik I: Elektrodynamik und Optik*, de Gruyter, Berlin, 1970 (German).
- [55] ———, *Einführung in die Theoretische Physik II: Theorie der Wärme, Molekular-kinetische Theorie*, de Gruyter, Berlin, 1970 (German).
- [56] S. Selberherr, *Analysis and simulation of semiconductor devices*, Springer, Wien, 1984.
- [57] Arnold Sommerfeld, *Electrodynamics. Lectures on theoretical physics, Vol. III*, Academic Press Inc., New York, N. Y., 1952, Translated by Edward G. Ramberg.
- [58] Barna A. Szabó and Zohar Yosibash, *Numerical analysis of singularities in two dimensions. II. Computation of generalized flux/stress intensity factors*, Internat. J. Numer. Methods Engrg. **39** (1996), 409–434.
- [59] Fred D. Tappert, *The parabolic approximation method*, Wave Propagation and Underwater Acoustics (Joseph B. Keller and John S. Papadakis, eds.), Lecture Notes in Physics, vol. 70, Springer, Berlin, 1977, pp. 224–287.
- [60] Wei-Cheng Wang, *A jump condition capturing finite difference scheme for elliptic interface problems*, SIAM J. Sci. Comput. **25** (2004), 1479–1496 (electronic).
- [61] Weichung Wang, Tsung-Min Hwang, Wen-Wei Lin, and Jinn-Liang Liu, *Numerical methods for semiconductor heterostructures with band non-parabolicity*, J. Comput. Phys. **190** (2003), 141–158.
- [62] C. Weisbuch and B. Vinter, *Quantum semiconductor structures: Fundamentals and applications*, Academic Press, Boston, 1991.
- [63] M. C. M. Wright, *The Wiener-Hopf technique*, Lecture notes on the mathematics of acoustics, Imperial College Press, London, 2005, pp. 109–124.
- [64] Zohar Yosibash and Netta Omer, *Numerical methods for extracting edge stress intensity functions in anisotropic three-dimensional domains*, Comput. Methods Appl. Mech. Engrg. **196** (2007), 3624–3649.